

Magnet Controller

Instruction and Parts Manual

ACS 50 AMP — ACS 175 AMP

Instruction and Parts Manual

ACS 100-175 AMP
Controller

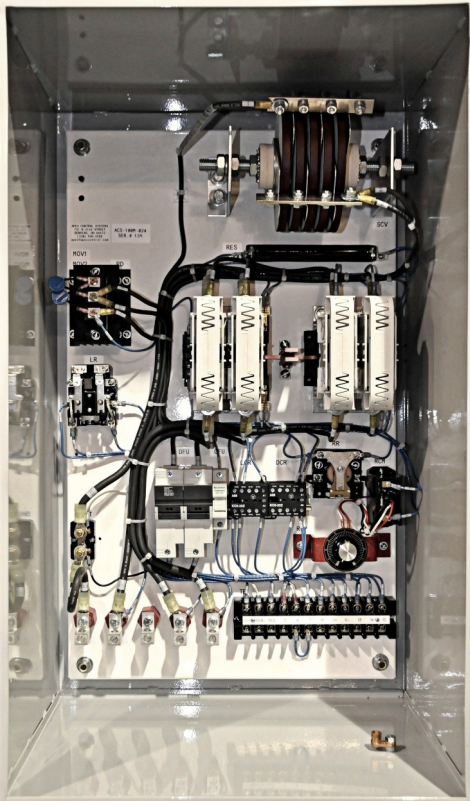

Rated 5-175 AMPS

ACS 50 AMP
Controller

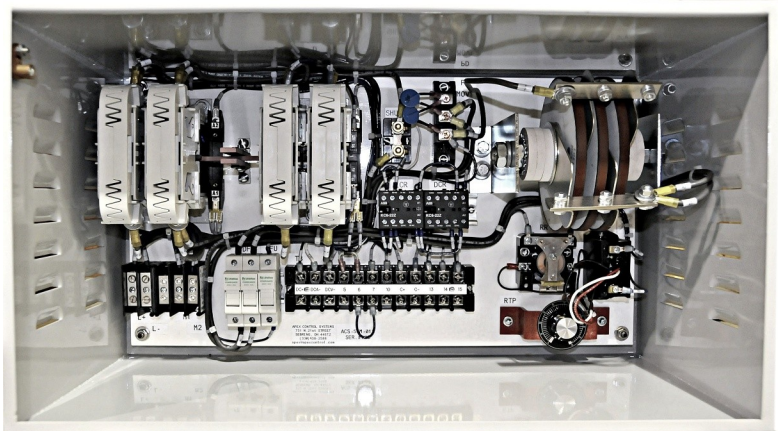

Rated 5-50 AMPS

Mill Duty Contactors
Automatic Varistor Discharge
Custom Options Available
Outdoor Rated

NASCO-OP™
Power of Numbers
800-321-3396

Magnet Controller

ACS 50 AMP — ACS 175 AMP

Instruction and Parts Manual

The information provided in this manual covers basic maintenance and troubleshooting information for all Apex Magnet Controllers. Please maintain all standard safety precautions and accepted installation practices when working with this equipment.

INDEX

50 AMP Controller Description & Schematicpg. 3
100 - 175 AMP Controller Description & Schematicpg. 5
Installation and Maintenance Informationpg. 7
Troubleshooting Guidepg. 8
Contactor Informationpg.10
Contactor Troubleshooting Guidepg. 13

Have questions?

Can't find what you're looking for?

We can help.



Standard Part Numbers

Apex Magnet Controllers are available in a variety of standard control voltages and current ratings, and can also be customized to meet specific requirements. To assist in troubleshooting and replacing parts, part numbers can be easily broken apart for accurate identification of the controller, as seen in the table below. So we can provide you with the best assistance possible, please be prepared to reference the serial number of your magnet controller when contacting us. Serial numbers are located on a white label within the enclosure itself, generally on the back wall.

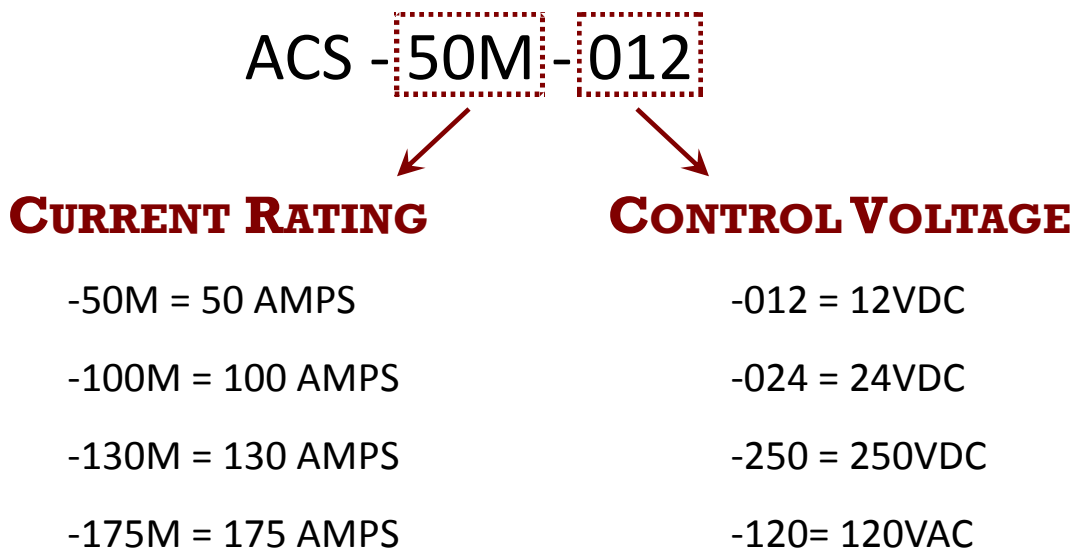

Magnet Controller

ACS 50 AMP — ACS 175 AMP

Instruction and Parts Manual

ACS 50 AMP Magnet Controller

- ⇒ Enclosure Dimensions: 14" H x 25"W x 13.215" D
- ⇒ Automatic Varistor Discharge (*Discharge Resistors available upon request*)
- ⇒ Control voltage options available : 12VDC, 24VDC, or 120VAC
- ⇒ NEMA 3R

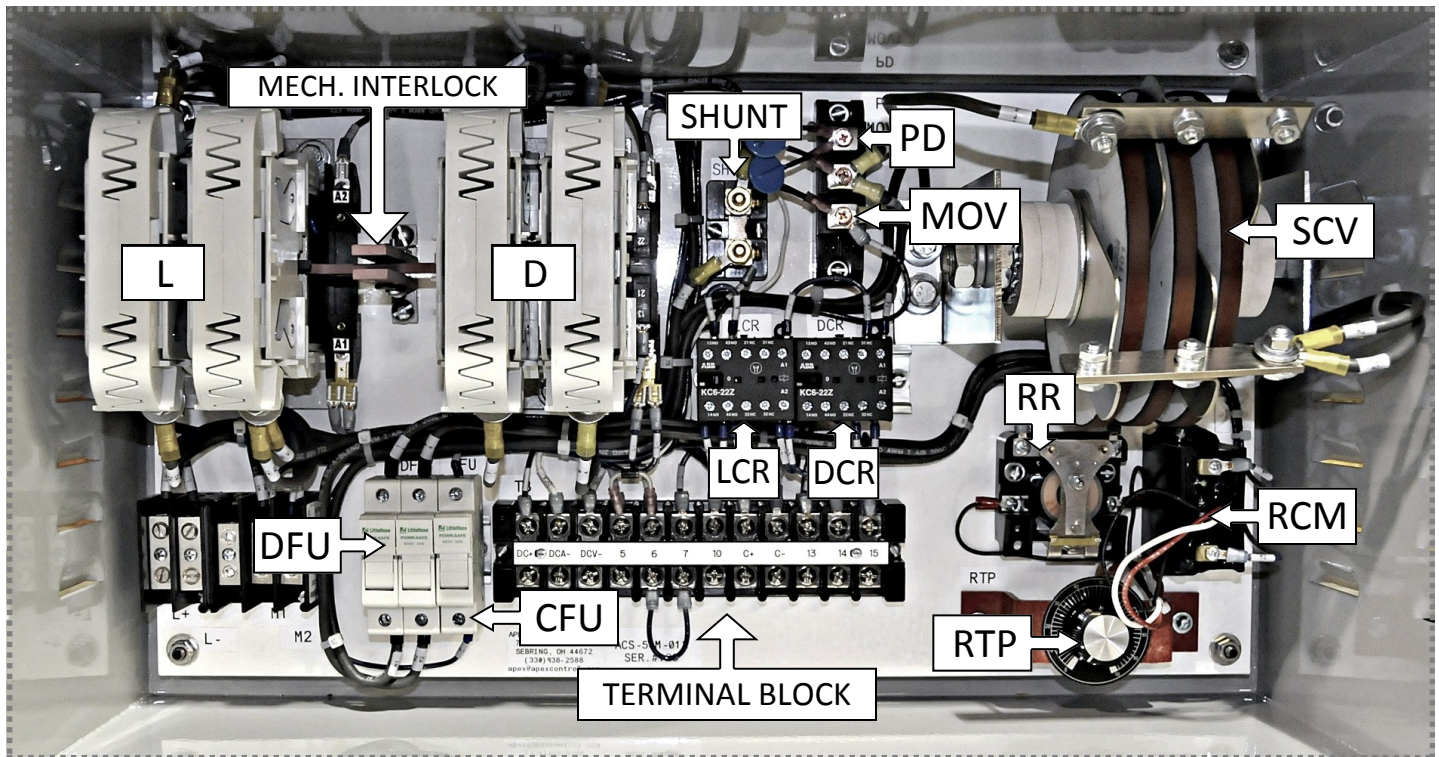

SCV	SILICONE CARBIDE VARISTOR
RR	REVERSE RELAY
RTP	REVERSE TIMING POTENTIOMETER
CFU	CONTROL FUSE
DFU	DROP FUSE
PD	POWER DIODE

RCM	REVERSE CIRCUIT MODULE
D	2 POLE DROP CONTACTOR
L	2 POLE LIFT CONTACTOR
MOV	SURGE SUPPRESSOR
LCR	LIFT CONTROL RELAY
DCR	DROP CONTROL RELAY
CD	CONTROL DIODE

Magnet Controller

ACS 50 AMP — ACS 175 AMP

Instruction and Parts Manual

ACS 50 AMP Magnet Controller Schematic

SCV	SILICONE CARBIDE VARISTOR
RR	REVERSE RELAY
RTP	REVERSE TIMING POTENTIOMETER
CFU	CONTROL FUSE
DFU	DROP FUSE
PD	POWER DIODE
RCM	REVERSE CIRCUIT MODULE
D	2 POLE DROP CONTACTOR
L	2 POLE LIFT CONTACTOR
MOV	SURGE SUPPRESSOR
LCR	LIFT CONTROL RELAY
DCR	DROP CONTROL RELAY
CD	CONTROL DIODE

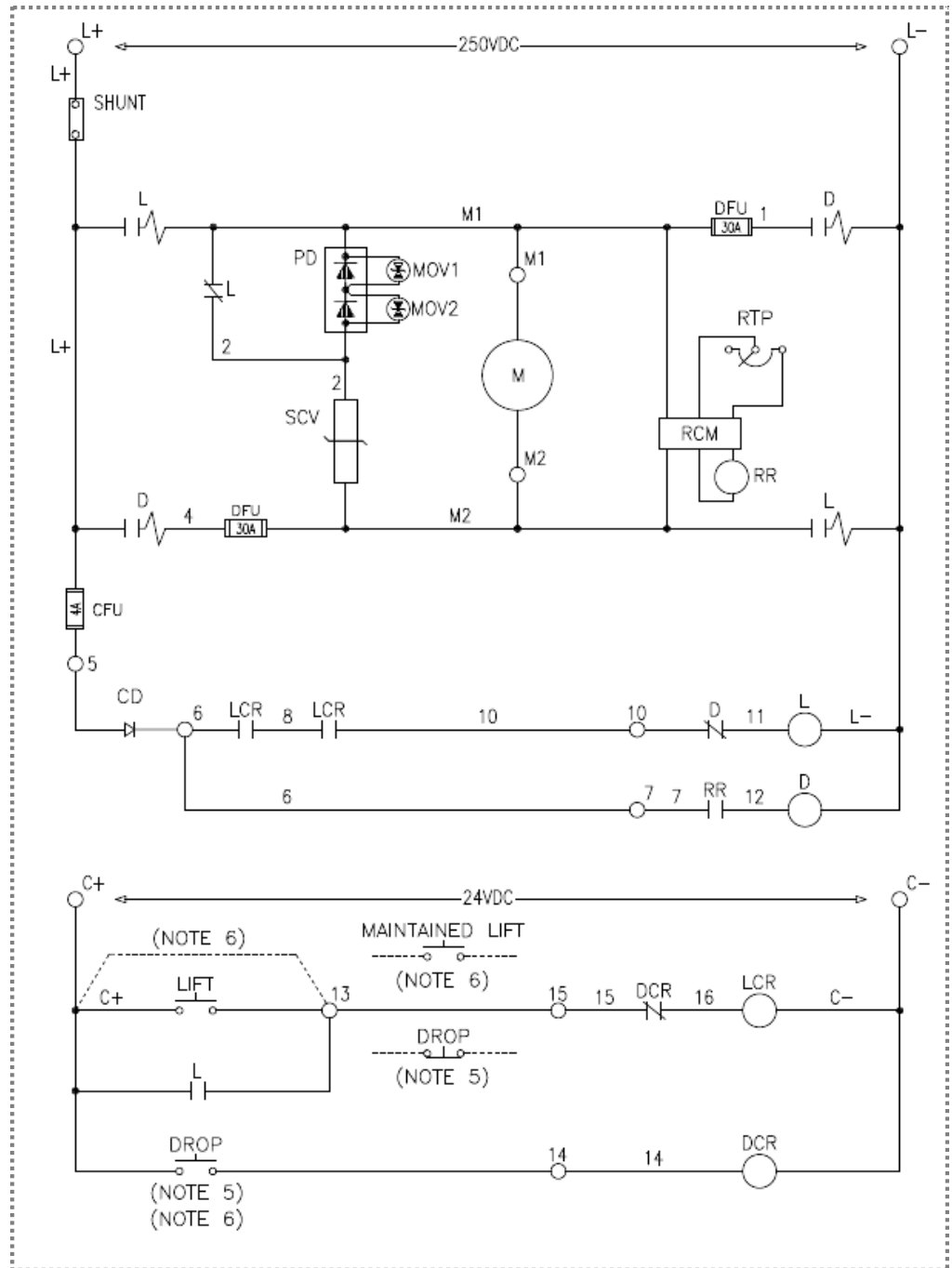

* 24VDC control shown in this schematic

Magnet Controller

ACS 50 AMP — ACS 175 AMP

Instruction and Parts Manual

ACS 100 - 175 AMP Magnet Controller

⇒ Enclosure Dimensions:

31.75" H x 19"W x 14.86" D

⇒ Control voltage options available :

12VDC, 24VDC, or 120VAC

⇒ NEMA 3R

SCV	SILICONE CARBIDE VARISTOR
RR	REVERSE RELAY
RTP	REVERSE TIMING POTENTIOMETER
CFU	CONTROL FUSE
DFU	DROP FUSE
PD	POWER DIODE
RCM	REVERSE CIRCUIT MODULE
D	2 POLE DROP CONTACTOR
L	2 POLE LIFT CONTACTOR
MOV	SURGE SUPPRESSOR
LR	LIFTING RELAY
CD	CONTROL DIODE
RES	RESISTOR

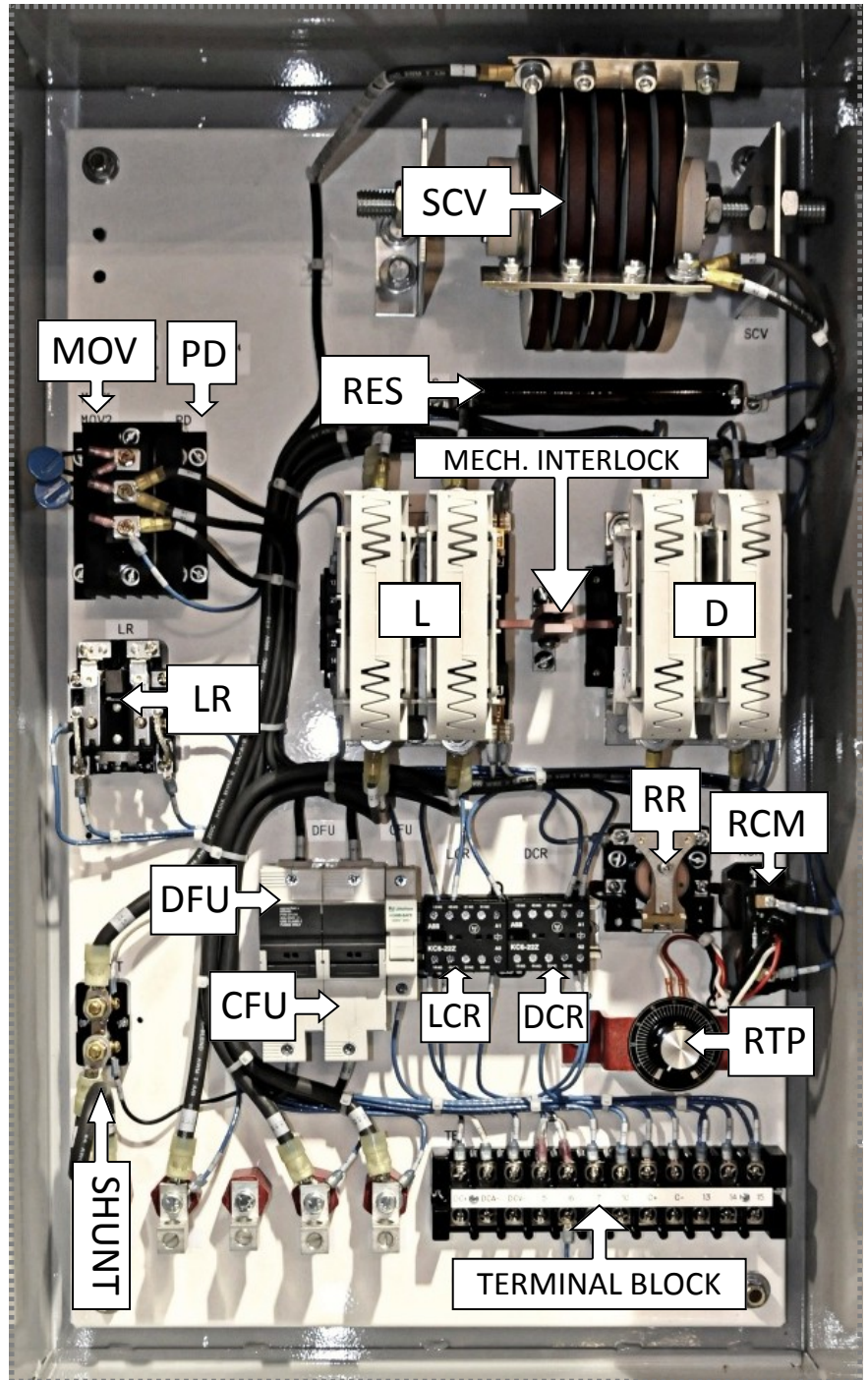

Magnet Controller

ACS 50 AMP — ACS 175 AMP

Instruction and Parts Manual

ACS 100-175 AMP Magnet Controller Schematic

SCV	SILICONE CARBIDE
RR	REVERSE RELAY
RTP	REVERSE TIMING POTENTIOMETER
CFU	CONTROL FUSE
DFU	DROP FUSE
PD	POWER DIODE
RCM	REVERSE CIRCUIT MODULE
D	2 POLE DROP CONTACTOR
L	2 POLE LIFT CONTACTOR
MOV	SURGE SUPPRESSOR
LR	LIFTING RELAY
CD	CONTROL DIODE
RES	RESISTOR

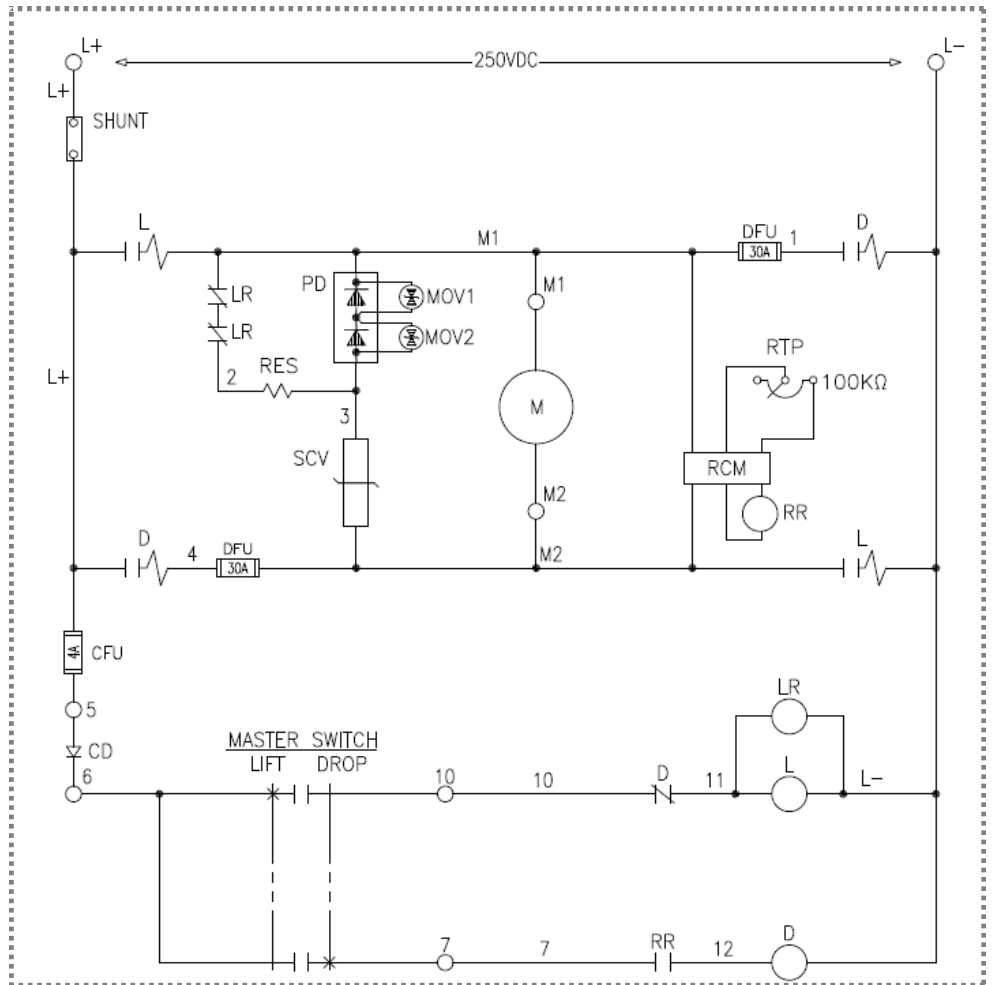

**250VDC control shown in this schematic*

Installation and Maintenance

Apex Magnet Controllers are available with 230VDC, 120VAC, 24VDC or 12VDC control circuits. When installing Apex Magnet Controllers, please maintain accepted installation practices and safety standards. With this in mind, it is very important to ensure that the proper control voltage is applied to the controller and to understand that these controllers will not function if the polarity of incoming line connections is not observed.

Obtaining a general understanding of basic principles of operation will greatly assist in troubleshooting and maintenance and will serve to keep the magnet controller working as efficiently as possible. Magnet operations require three main functions. First, the magnet must be energized for the load to be moved. Second, the stored energy generated by the magnet must be dissipated for the magnet to release the load. Finally, a reverse current must be applied through the magnet to remove any residual magnetism that may exist.

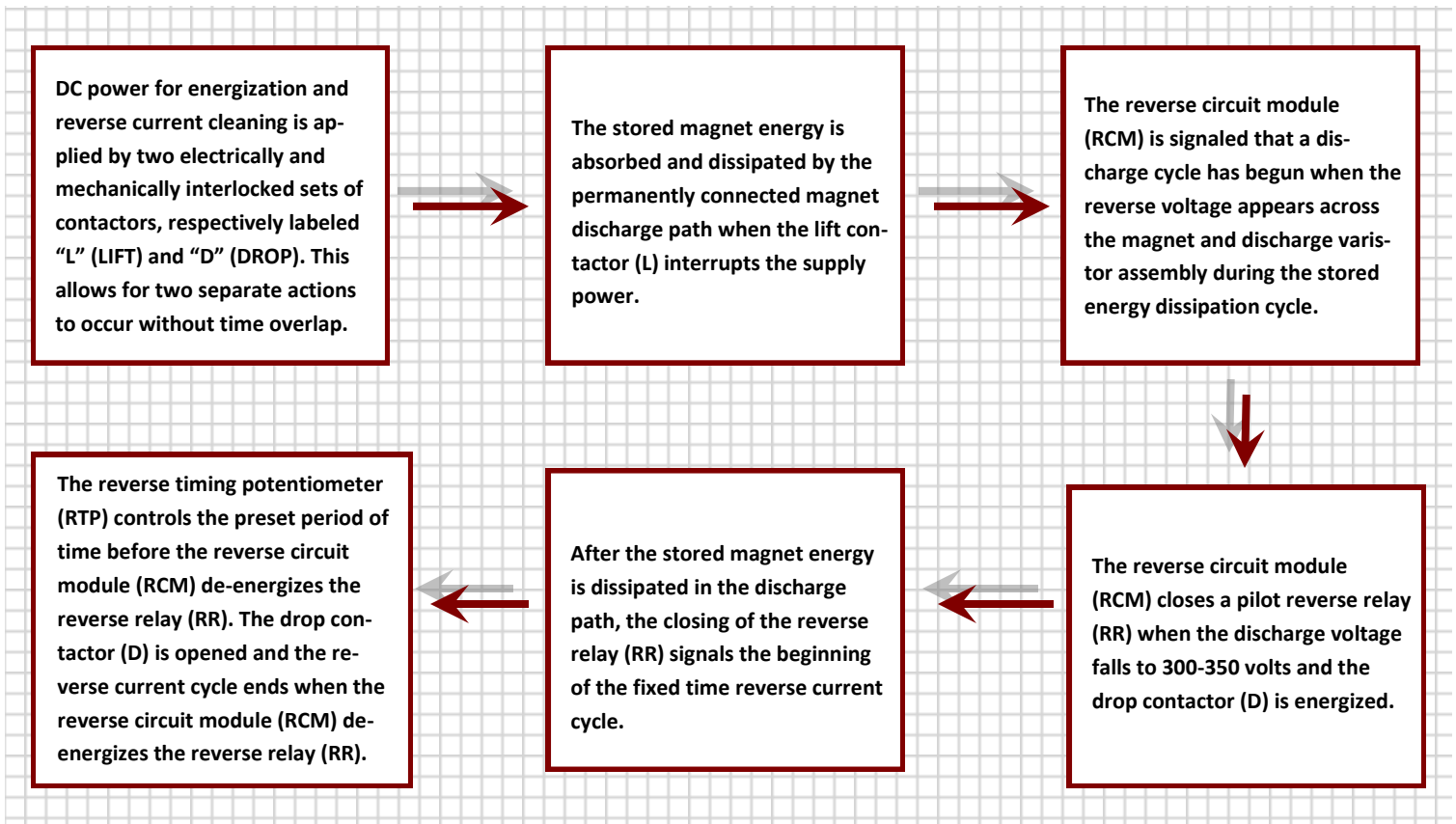

To adjust the reverse current time:

- ⇒ Use the lightest material handled by the controller
- ⇒ Locate the reverse timing potentiometer (RTP) which is mounted beside the RCM
- ⇒ Start with the reverse timing potentiometer (RTP) at zero and cycle the controller
- ⇒ Turn the adjustment knob clockwise and repeat cycling until the magnet drops the material cleanly

Troubleshooting Guide

SYMPTOM	POSSIBLE CAUSE	DIAGNOSIS
<p><i>Magnet does not clean properly.</i></p> <p><i>*Controls 100 AMP and larger use a resistor (RES), in conjunction with the varistor (SCV) to clean the magnet. Note that the magnet will not properly clean if this resistor circuit is OPEN.</i></p>	No reverse current flows, but drop contactor operates.	Drop fuses (DFU) need replaced.
	Silicone carbide varistor (SCV) circuit is open.	Check SCV for obvious defects such as warped fins. Additionally, the SCV may leak when overheated, leaving behind a brownish residue from paraffin wax embedded within the SCV. Replace SCV varistor.
	Drop contactor (D) does not remain closed long enough to clean magnet. Reverse current cycle time is too short .	<i>Increase</i> the reverse timing potentiometer (RTP) setting. (counter-clockwise rotation)
	Drop contactor (D) remains closed too long and allows excessive current to build up. Reverse current cycle time is too long .	<i>Decrease</i> the reverse timing potentiometer (RTP) setting. (clockwise rotation)
<p><i>Magnet discharge device overheats.</i></p>	Power diode (PD) is shorted. Full line voltage applied to magnet discharge device during lift cycle.	Replace power diode (PD) .
	Too many magnet discharges per minute.	Avoid frequent cycling or use controller with greater capacity.
<p><i>No adjustment of the reverse current cycle.</i></p>	Faulty drop reverse time potentiometer (RTP).	Replace potentiometer assembly.
	Faulty reverse circuit module (RCM).	Replace the RCM.
<p><i>Lift contactor (L) does not pick up.</i></p>	Control fuse (CFU) or Diode (D1) open.	Replace CFU or D1.
	Lift contactor coil circuit open.	Check continuity of lift contactor coils. Check master switch contacts.
	Polarity not observed at the time of controller installation.	Reverse the supply power connections to the controller.

Troubleshooting Guide

<p><i>Drop contactor (D) does not operate.</i></p> <p><i>*Note that the drop contactor will not operate without magnet connected in circuit.</i></p>	Reversed M2-M1 connections to reverse circuit module (RCM).	Check RCM wiring and correct if necessary.
	Faulty reverse relay (RR).	Replace reverse relay (RR).
	Drop contactor (D) coil circuit open.	Check continuity of drop contactor coils. Check master switch contacts.
	Faulty reverse circuit module (RCM).	Replace RCM.
<p><i>Drop contactor (D) operates but does not drop.</i></p>	Faulty reverse timing potentiometer (RTP) or open potentiometer circuit.	Repair or replace RTP assembly or wiring.
	Faulty reverse circuit module (RCM).	Replace RCM.

Magnet Controller

Instruction and Parts Manual

ACS 50 AMP — ACS 175 AMP

Contactor Information

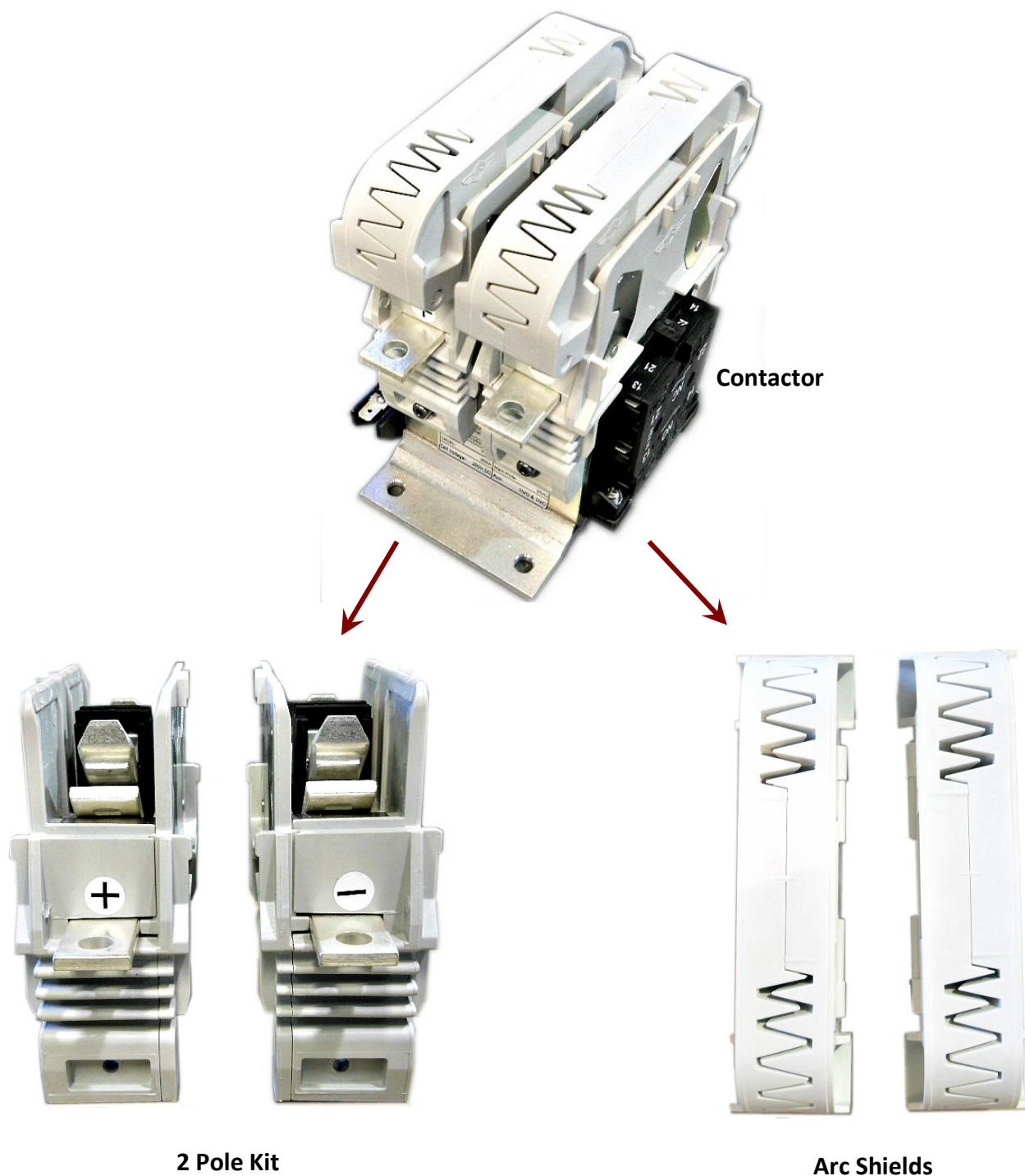

Magnet Controller

ACS 50 AMP — ACS 175 AMP

Instruction and Parts Manual

(Qty. 2) 2 Pole Contactor Kits for use with ACS 50 AMP—175 AMP Magnet Controllers

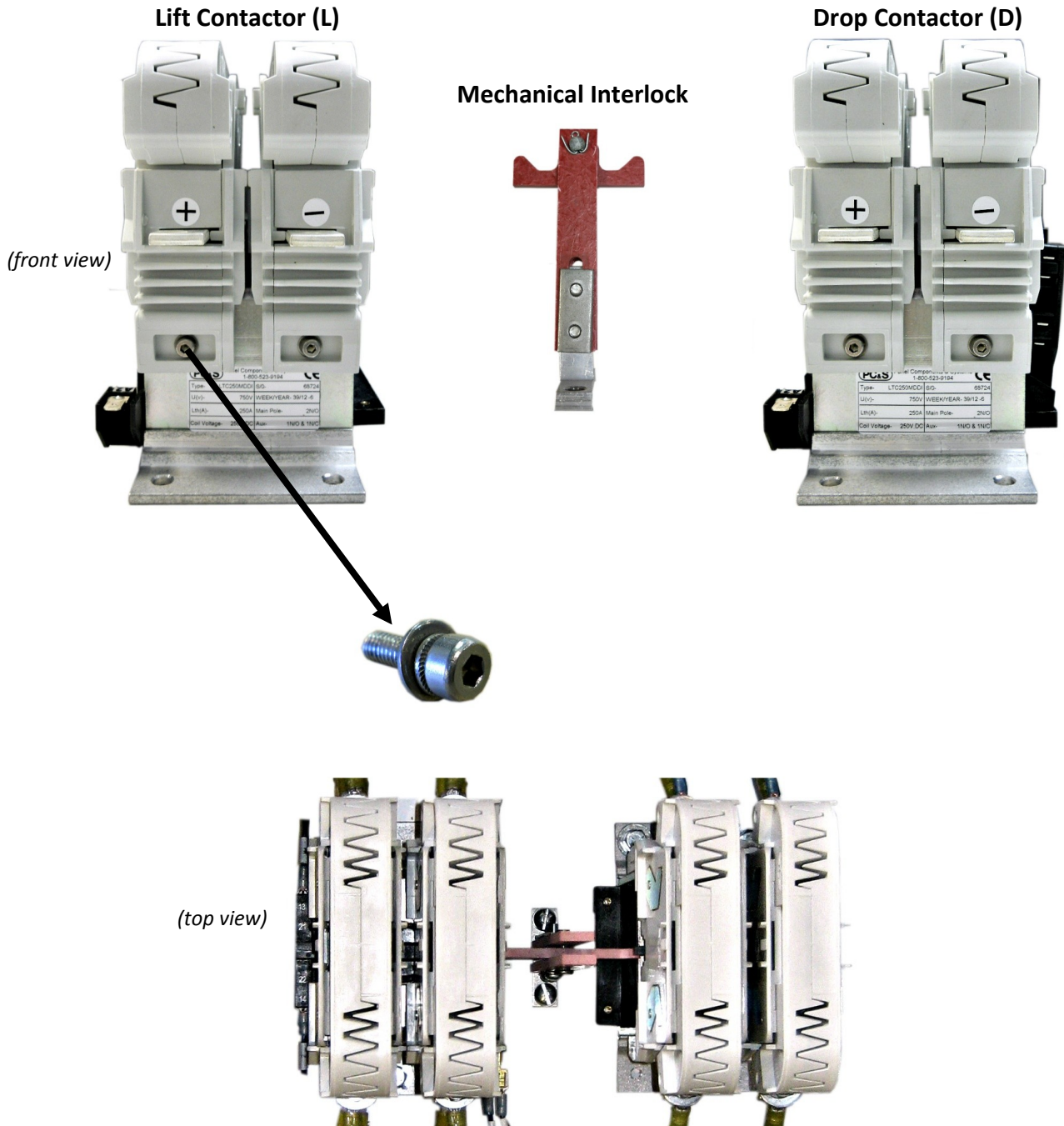

Magnet Controller

ACS 50 AMP — ACS 175 AMP

Instruction and Parts Manual

Spare Parts List

(one pole contactor shown)

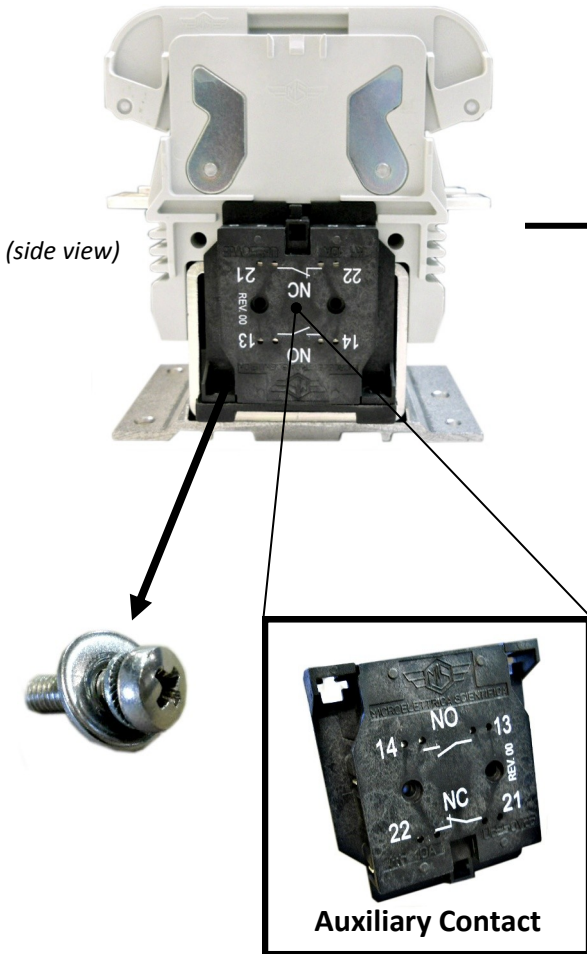

Arc Shield



Pole

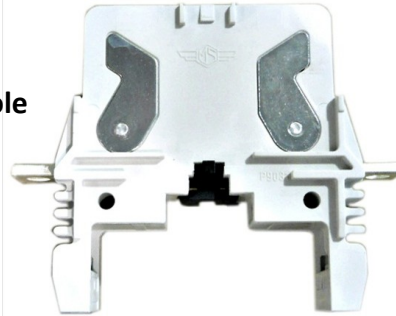

Coil Core Holder



Contactor Tie Bar



Coil Core



Coil Base



Coil

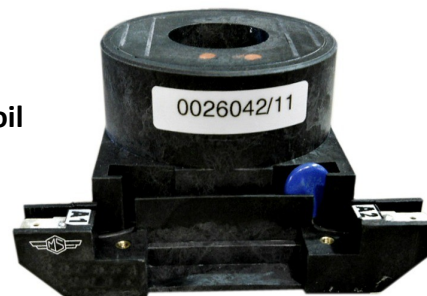

Contactor Troubleshooting Guide



CAUTION:

When performing maintenance activity, high voltage parts are exposed. To maintain safety, make sure that high voltage is disconnected before accessing the contactor.



General checks

- Remove dust or other deposits by airblast.
- Check that the connections are correctly tightened.
- Check that the contactor closes electrically at 55% of coil nominal voltage at 20° C.
- If the contactor does not close, the main coil needs to be checked, and eventually replaced.

Check the arc chute

- Remove the arc chute by pulling up on one end (1) and then lifting off the arc chute (2). See diagram A.
- To reassemble, follow the arrows in reverse order.
- Visually check the inside of the arc chute.
- Black arcing traces are to be expected. However, if the inner sides of the arc chute show signs of erosion by arcing traces (i.e. the side material is becoming thinner than expected); the arc chute needs to be replaced.

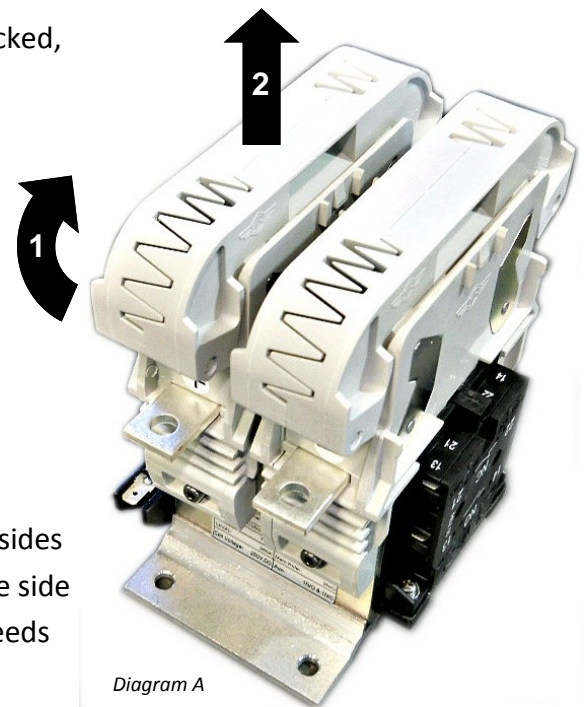

Diagram A

Check the wear of the main contacts

Main contacts must not be abraded/eroded, and must have a sufficient contact thickness. Check for any abnormal abrasions and proceed as follows :

- Push the movable contact to gradually close by pressing on top of its black holder.
- Verify that the contacts touch on both sides simultaneously.
- Verify that after all contact tips initially touch, the black plunger can still be pressed down by >1mm, compressing the pressure spring (1). *See diagram B.*
- If contact is made without pressure, or if abnormal abrasions are noticed, the complete pole needs to be replaced following replacement instructions.

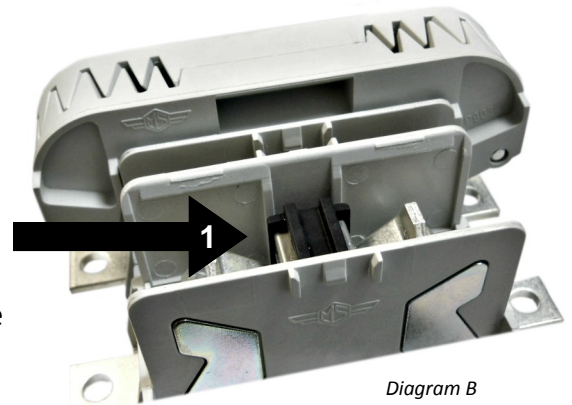

Diagram B

COMPLETE COIL REPLACEMENT

- Remove contactor from panel.
- Take off the arc chute, auxiliary contacts and pole as explained above.
- Loosen the coil holding screw at the bottom of the armature, using a 10mm wrench. Save all material removed.
- Pull out the magnetic core and slide out the coil.
- Replace the coil and reassemble following reverse order of operations. Apply tightening torque as indicated (12nM).

COMPLETE POLE REPLACEMENT

- Remove the arc chute as previously explained.
- Remove the auxiliary contact block using phillips screwdriver (tightening torque 5Nm). Save all material removed.
- Loosen and remove the fixing screws on the ends of the pole, using a 3mm allen wrench (tightening torque 8Nm). Save both screws and lock washers removed.
- Lift off the entire pole and remove the magnetic mobile core at its bottom. Save the core and replace the pole. Fit the core to the new pole and re-insert the pole on the fixed armature.
- Re-assemble following reverse order. Apply tightening torque as specified. After pole replacement no specified check is required, however, make sure that the mechanism moves freely, and that the contactor closes electrically at 22VDC.

Magnet Controller

ACS 50 AMP — ACS 175 AMP

Instruction and Parts Manual



*Still have questions?
Can't find what you're looking for?
We can help.*

