

OHIO MODEL MC-1.5A & MC-2.0A AUTO/MANUAL DROP MAGNET CONTROLLER

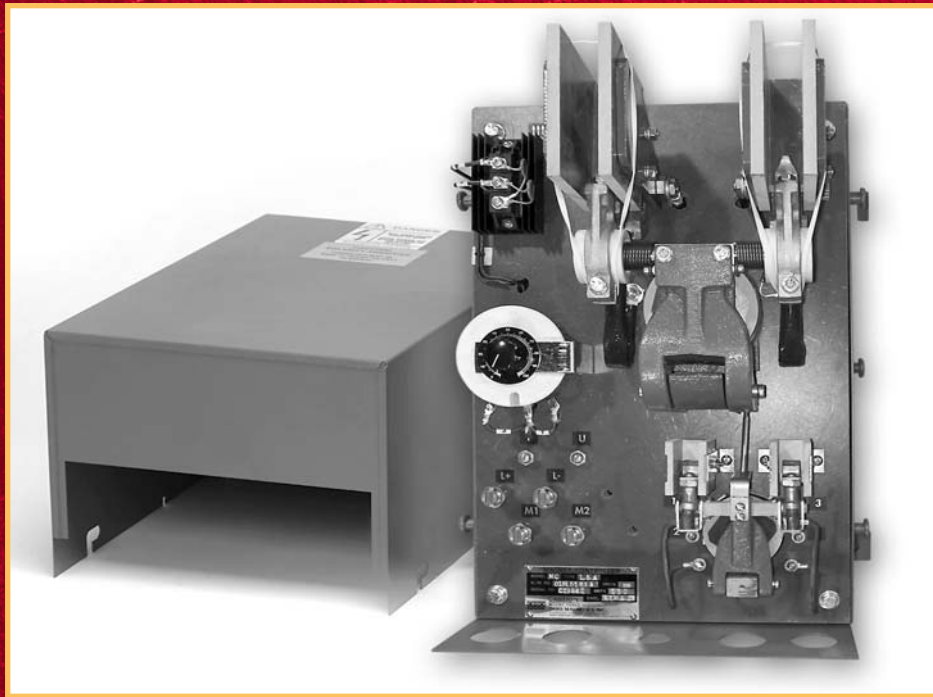

INSTALLATION, MAINTENANCE, AND PARTS BULLETIN

OPERATING RANGE
70-130 A (MC-1.5A) & 100-150 A (MC-2.0A)
(COLD MAGNET CURRENT)

DESCRIPTION

The MC-1.5A and 2.0A Controllers are heavy duty magnet controllers used for magnets whose cold current ranges from 70-130A and 100-150A. Cold current references the current flowing through the magnet when the magnet temperature is 25°C throughout.

AUTOMATIC DROP

A reverse current adjustment provides for a fast, clean drop of the magnet over a complete range of magnetic material with one movement of the master switch or push button.

MANUAL DROP

Allows for partial dropping of the load by controlling the amount of reverse current to the magnet. A drop position on the master switch or a push button that is spring returned to off, gives the operator complete control of the drop cycle.

INSTALLATION PROCEDURES

- Mount the controller to a solid surface with the mounting bars provided.
- The controller must be mounted vertically with the “TOP” up to operate properly.
- Mount the controller away from sources of heat and direct exhaust of engines.
- Allow enough room around the controller for air circulation.
- Route electrical wires through bottom of the enclosure and connect securely to the terminals.
- All electrical circuits must be free from grounds and shorts.
- Remove shipping material from the arc shields before operating the controller.
- Adjust the reverse current control rheostat to provide enough reverse current to cleanly drop the magnet load.

Procedure Start with the dial set at low range. Pick up and drop a load of the material to be handled. If the material does not completely fall off the magnet, increase the adjustment and try another load. If the material drops off and then some jumps back up to the magnet before it can fall free, reduce the adjustment and try another load. When all the material falls cleanly from the magnet, the controller is properly set.

MC-1.5A & MC-2.0A SUBASSEMBLIES

27 018B0217A

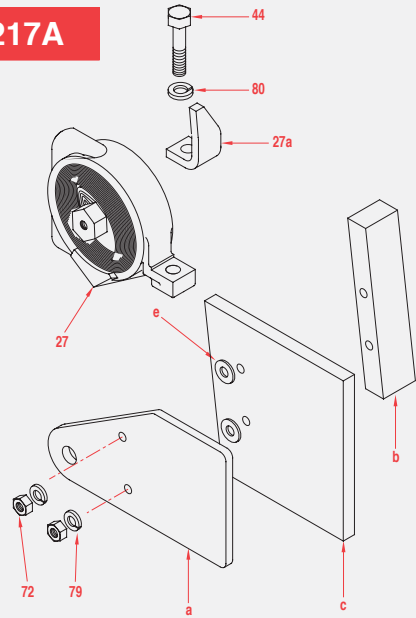

33 018C0216X

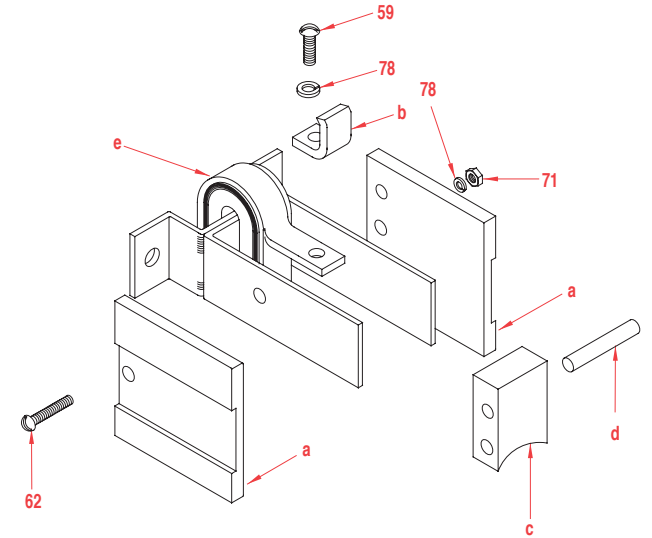
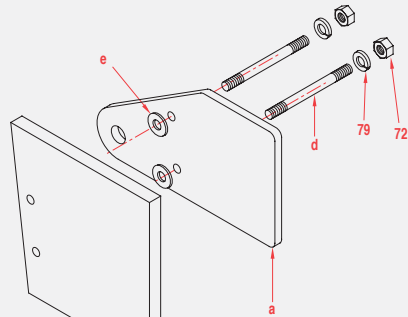

28 018B1478X

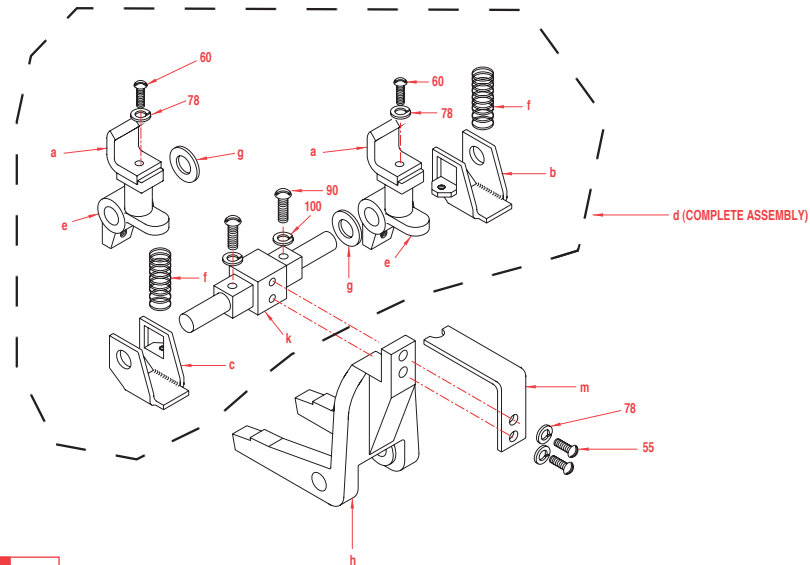

018B6368E **31**

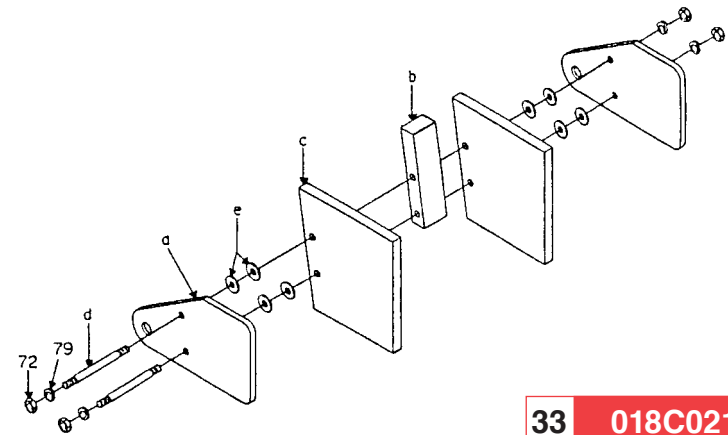
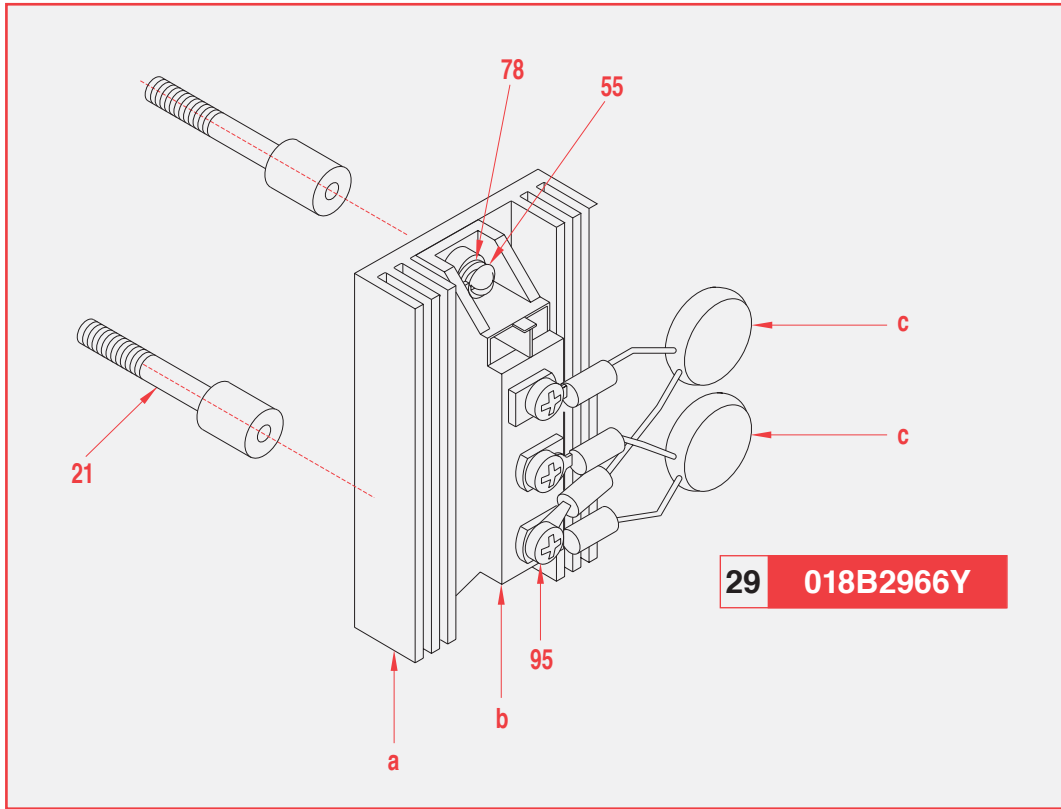

33 018C0216X

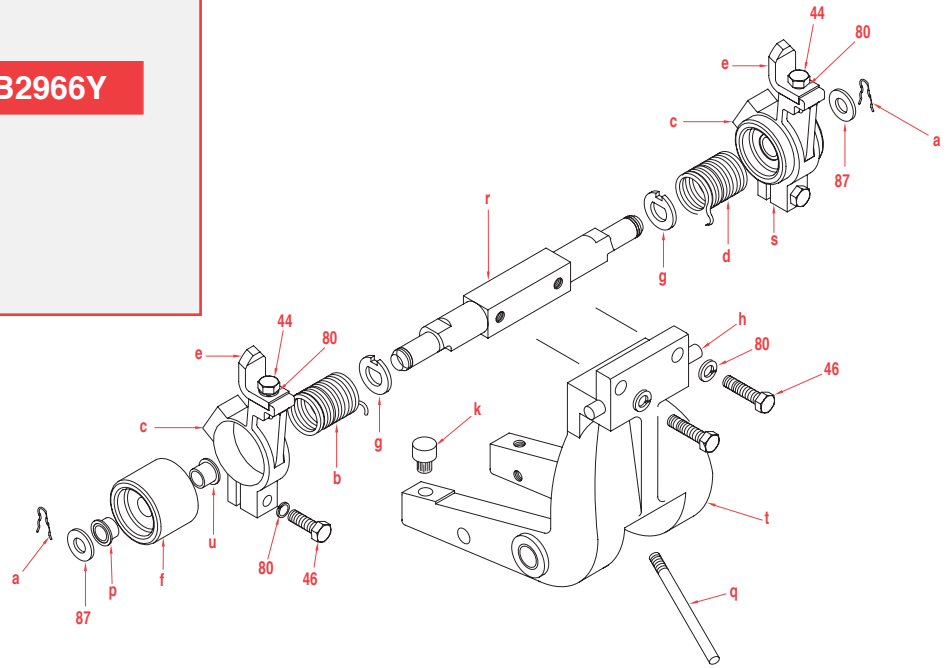

018D3090C 35

OHIO MODEL MC-1.5A & MC-2.0A AUTO/MANUAL DROP MAGNET CONTROLLER

MC-1.5A & MC-2.0A CONTROLLER EXPLODED ASSEMBLY VIEW

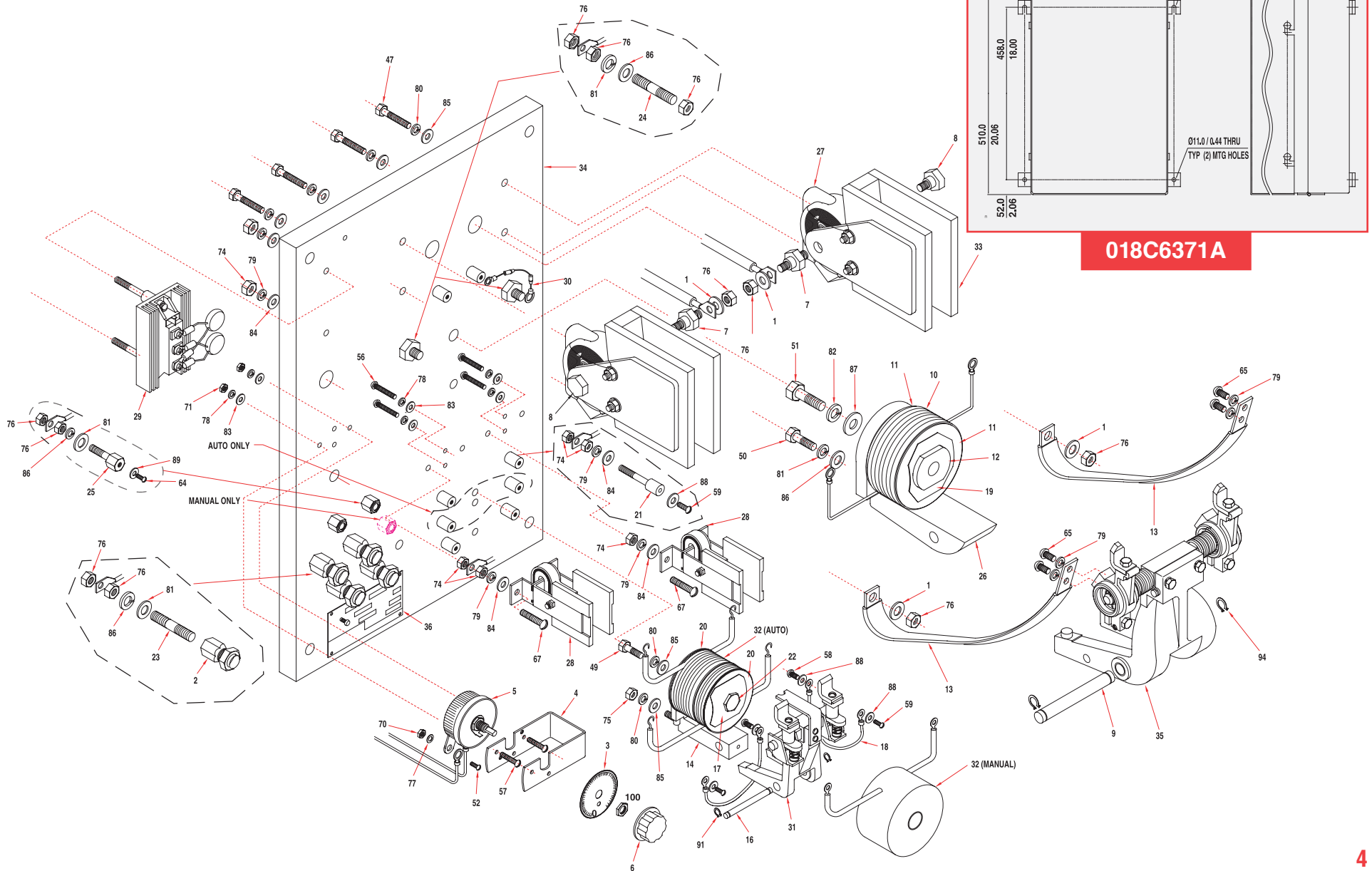

MC-1.5A & MC-2.0A WIRING DIAGRAMS

MC-1.5A & MC-2.0A AUTOMATIC CONTROLLER

WIRE DIAGRAM P/N: 018B6171X (230 V-dc) • 018B6171C (115 V-dc)

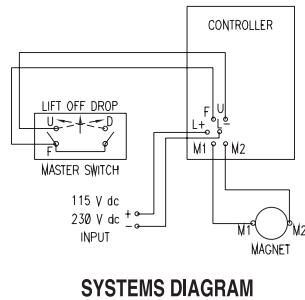
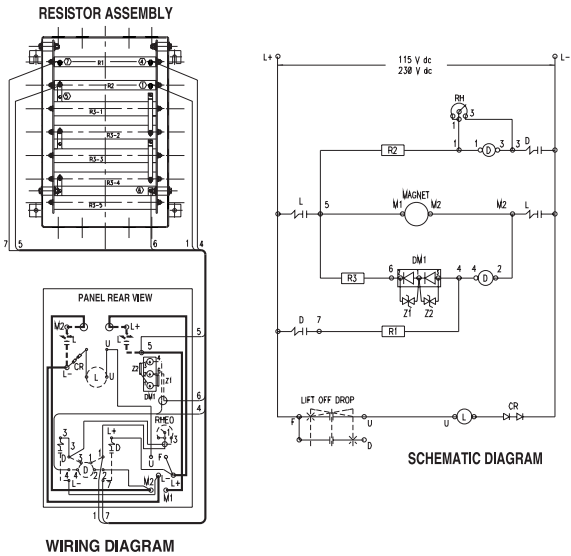

MC-1.5A & MC-2.0A MANUAL CONTROLLER

WIRE DIAGRAM P/N: 018B6171A (230 V-dc) • 018B6171D (115 V-dc)

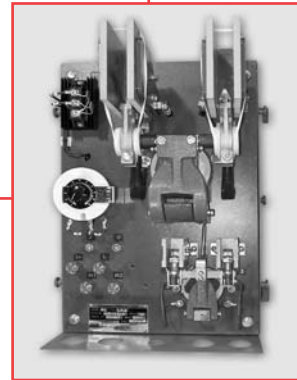
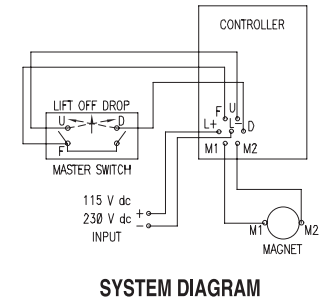
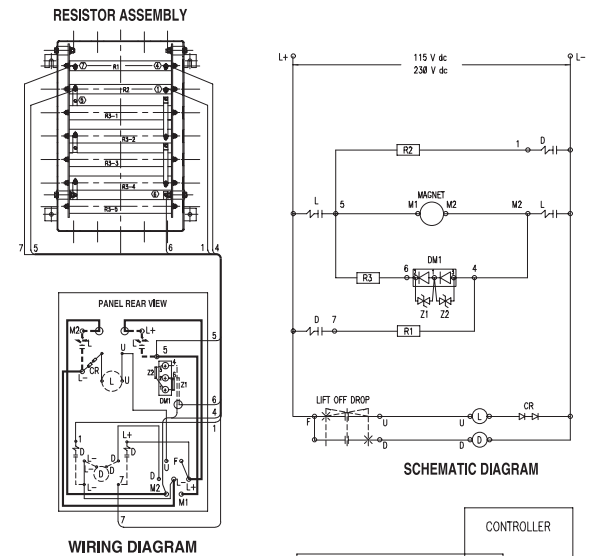

MC-1.5A & MC-2.0A AUTOMATIC CONTROLLER (Variable Voltage)

WIRE DIAGRAM P/N: 018B6171B (0~230 V-dc) • 018B6171E (0~115 V-dc)

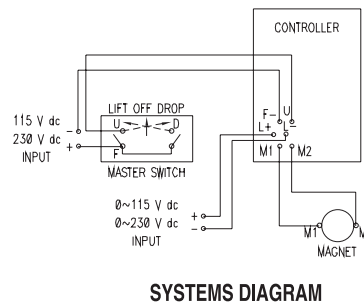
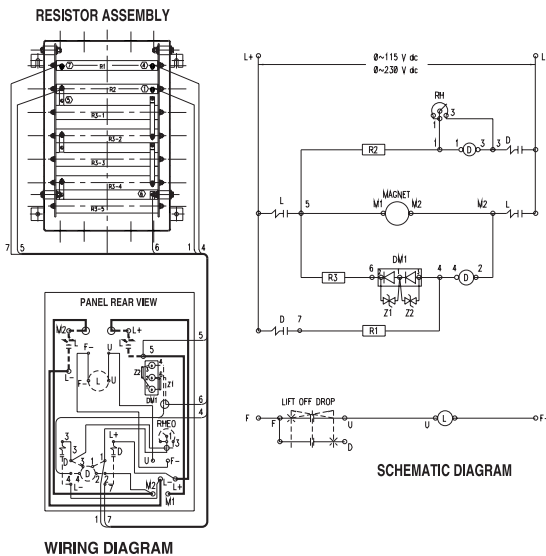

TABLE OF EQUIPMENT

SYMBOL	DESCRIPTION	FUNCTION
D	REVERSE CONTACT	DROP
L	MAIN CONTACT	LIFT
RH	0.5 Ω RHEOSTAT	DROP CONTROL
R1-R2	2.4 Ω RESISTOR	DROP RESISTOR (MC-2.0A-115V)
R1-R2	4.8 Ω RESISTOR	DROP RESISTOR (MC-2.0A-230V)
R3	12.8 Ω (2.56 Ω x 5) RESISTOR	DISCHARGE RESISTOR (MC-2.0A)
R1-R2	2.75 Ω RESISTOR	DROP RESISTOR (MC-1.5A-115V)
R1-R2	5.5 Ω RESISTOR	DROP RESISTOR (MC-1.5A-230V)
R3	15.0 Ω (3.0 Ω x 5) RESISTOR	DISCHARGE RESISTOR (MC-1.5A)
DM1	DIODE MODULE	BLOCKING DIODE
Z1-Z2	MOV SUPPRESSOR	DIODE PROTECTION
CR	CONTROL DIODE	ANTI-REVERSE PROTECTION

STEP BY STEP CONTROLLER OPERATION

AUTOMATIC CONTROLLER

1. When a lift signal is given by closing the contacts between terminals “F” and “U”, the “L” coil is energized.
2. This closes the “L” contacts which supplies full power to the magnet.
3. When a drop signal is given the “F” to “U” contact is broken and the “L” coil is de-energized.
4. This opens the “L” contacts and at the same time allowing current to flow through blocking diode DM1.
5. A discharge circuit is set up through resistor “R3” and the “4,” “2” winding of the “D” coil, (energizing the coil).
6. This causes the energy in the magnet to be dissipated through the “R3” resistor, and the “D” contacts to close.
7. Reverse voltage is then applied to the magnet through the “R1” and “R2” resistors.
8. When the proper amount of reverse current to the magnet, (as adjusted by the rheostat), is measured by the “4,” “2” winding of the “D” coil, it cancels the affect of the “1,” “3” winding of the “D” coil and the “D” contacts open.
9. This stops the flow of reverse current through the magnet.

MANUAL CONTROLLER

1. When a lift signal is given by closing the contacts between terminals “F” and “U”, the “L” coil is energized.
2. This closes the “L” contacts which supplies full power to the magnet.
3. When a drop signal is given the “F” to “U” contact is broken and the “L” coil is de-energized.
4. This opens the “L” contacts and allows current to flow through blocking diode DM1.
5. A discharge circuit is set up through resistor “R3”.
6. Energy in the magnet is dissipated through the “R3” resistor.
7. Moving the master switch to the drop position or pushing the drop button, closes the contact between terminals “F” and “D”, energizing the “D” coil.
8. This closes the “D” contacts and provides reverse voltage to the magnet, through resistors “R1” and “R2”.
9. To stop the build up of reverse current, release the master switch control and it will return to the off position, or release the drop push button.
10. This breaks the contact between the “F” and “D” terminals, de-energizes the “D” coil, (opening the “D” contacts), and stops the flow of reverse current through the magnet.

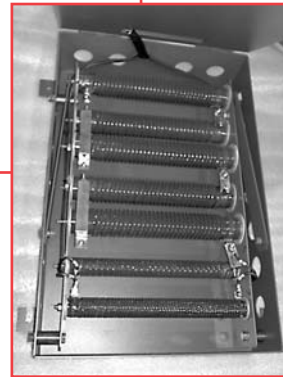

MC-1.5A & MC-2.0A RESISTOR ASSEMBLY CONTROLLER

RESISTOR ASSEMBLY CONTROLLER MC-1.5A

115/230 V-dc WITH DIODE
018A8108C (230 V-dc)
018A8108E (115 V-dc)

RESISTOR ASSEMBLY CONTROLLER MC-2.0A

115/230 V-dc WITH DIODE
018A8101W (230 V-dc)
018A8101Y (115 V-dc)

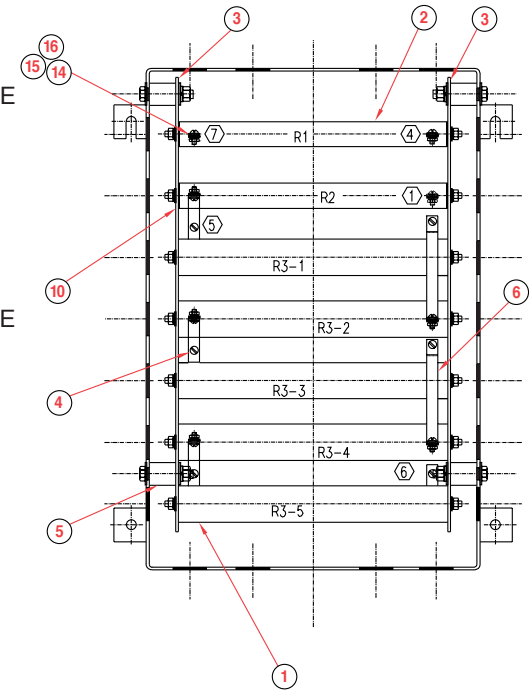

NO.	PART NUMBER	QTY	DESCRIPTION
1	A-900241-98	5	RESISTOR, 500 W, 3.0 Ω MC-1.5A
1	A-900241-97	5	RESISTOR, 500 W, 2.56 Ω MC-2.0A
2	A-900241-99	2	RESISTOR, 400 W, 5.5 Ω 230 V-dc MC-1.5A
2	A-900241-100	2	RESISTOR, 400 W, 2.75 Ω 115 V-dc MC-1.5A
2	A-900241-95	2	RESISTOR, 400 W, 4.8 Ω 230 V-dc MC-2.0A
2	A-900241-101	2	RESISTOR, 400 W, 2.4 Ω 115 V-dc MC-2.0A
3	018B8101X	2	MTG. BRACKET
4	018A8114E	3	BUS BAR
5	1900A006003	4	SPACER: 30 mm
6	018B8114F	2	BUS BAR
7			
8			
9			
10	018A1500X	4	MICA WASHER
11			
12			
13			
14	A-900417-07	14	M5 X 0.8 X 16 mm PAN HD SCREW
15	A-900106-39	14	M5 X 0.8 X 16 HEX NUT
16	A-900116-12	28	M5 X LOCK WASHER INT TOOTH

MAINTENANCE AND TROUBLE SHOOTING

Check all contact tips for excess wear or burning. Replace if needed.

Check arc shields for burnt areas. Replace any that are badly burned.

Check for burned or damaged insulation on shunts or wires. Replace if found.

Check for carbon tracking on the base panel and insulating parts. If found, remove by filing or scraping. If carbon can not be removed, replace the part.

Check gap ($\frac{3}{4}$ " (20 mm) opening) between main contacts (#27a and #35e). Adjust by loosening screw (#46) on part (#35c) and turning the assembly.

All pin connections should move easily, and contact springs should provide force when contacts are closed. If springs do not provide contact force, replace them.

Check Power Diode Integrity (DM1) with a standard Digital Volt Meter (DVM), set to the diode check function. (See owner's manual for details.) Disconnect leads to the diode and remove suppressors MOV (Z1 and Z2) to isolate from the circuit. Place the red lead of meter on Terminal 1 of diode (number is stamped next to terminal) and the black lead on Terminal 2. Meter should read <1.0. Reverse leads and meter should read 1.(00). Repeat for Terminals 3 (red) and 1 (black). If the diode reads bad, replace. Reconnect wires and MOVs (Z1 and Z2).

NOTE: Z1 and Z2 are MOV suppressors to help limit voltage spikes applied to DM1 and causing damage.



EMERGENCY SPARE PARTS KITS AND/OR KITS

Automatic — #ESP-018M7020A1

- Contains the parts most likely to fail due to a system problem or a high voltage spike. It is recommended that one of these kits be kept on hand to avoid unnecessary down time.



OHIO MAGNETICS—PERFORMANCE ENGINEERED



Stearns