

CLS

Cargo Lift Scale

Installation Manual

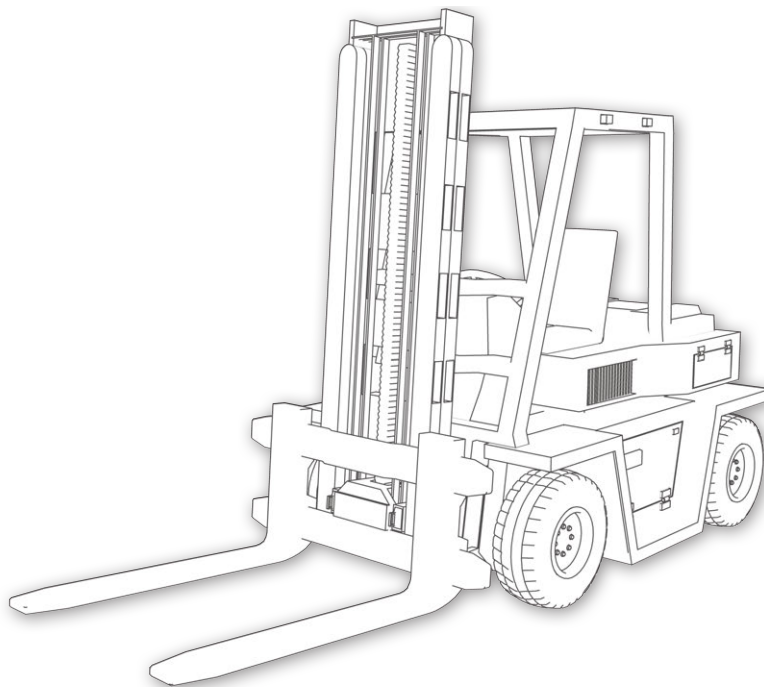

An ISO 9001 registered company
© Rice Lake Weighing Systems. All rights reserved.

Rice Lake Weighing Systems® is a registered trademark of
Rice Lake Weighing Systems.

All other brand or product names within this publication are trademarks or
registered trademarks of their respective companies.

All information contained within this publication is, to the best of our knowledge, complete and
accurate at the time of publication. Rice Lake Weighing Systems reserves the right to make
changes to the technology, features, specifications and design of the equipment without notice.

The most current version of this publication, software, firmware and all other product
updates can be found on our website:

Contents

1.0 Introduction	1
1.1 Scale Carriage Features	1
1.2 Safety	2
1.3 Considerations Before Installation	3
1.3.1 Forklift Derating	3
1.4 CLS-IM Junction Box	4
2.0 Installation	5
2.1 Unpacking	5
2.1.1 Unpacking One Scale Configuration	6
2.1.2 Unpacking Two Scale Configuration	8
2.2 Before Installation	9
2.3 Tools Required for Installation	10
2.4 Scale Base Installation	11
2.5 Install Forks	13
2.6 Connect Coiled Interface Cable to Junction Box	13
2.6.1 Route the Load Cell Coiled Interface Cable	14
3.0 Parts and Service	15
3.1 Daily Inspection Checklist	15
3.2 Cargo Lift Scale Assembly	16
3.2.1 Load Cell Assembly	17
3.2.2 CLS-IM Junction Box Assembly (PN 191642)	18
3.3 CLS-IM Junction Box Maintenance/Upgrade	19
3.3.1 CLS-IM Replacement	19
3.3.2 CLS-IM PCB Board Assembly Replacement	20
3.4 Load Cell Maintenance	21
3.4.1 Required Tools for Replacing a Load Cell	21
3.4.2 Load Cell Replacement	22
3.4.3 Forklift Flexure Troubleshooting	29
4.0 Troubleshooting	30
4.1 Troubleshooting Chart	30
5.0 CLS Specifications	31



Technical training seminars are available through Rice Lake Weighing Systems. Course descriptions and dates can be viewed at www.ricelake.com/training or obtained by calling 715-234-9171 and asking for the training department.



Rice Lake continually offers web-based video training on a growing selection of product-related topics at no cost. Visit www.ricelake.com/webinars

1.0 Introduction

The Cargo Lift Scale (CLS) is a rugged, dependable scale that can withstand many years of repeated use. When mounted on a forklift, the CLS saves time and money by allowing loads to be weighed immediately instead of carrying the load to a floor scale and then to its final destination.

This manual is intended for use by individuals responsible for installing the cargo lift scale. This includes information on the installation and maintenance of the scale carriage and signal cable installation (if applicable).



Manuals and additional resources are available from the Rice Lake Weighing Systems website at www.ricelake.com

Warranty information can be found on the website at www.ricelake.com/warranties

1.1 Scale Carriage Features

- Compatible with Class II (16 inch high) forklift cleat type carriages
- Out of level NTEP Certified tolerance at five degrees backward, three degrees forward and three degrees side to side
- 1 1/2 inch thick front and back painted steel plates coupled by four flexure's
- Top cleats are welded, pinned and bolted
- Welded centering pin
- Two 5,000 lb S-beam load cells
- CLS-IM junction box
- Molded coiled cable, up to 15 feet uncoiled

1.2 Safety

Safety Signal Definitions:



DANGER Indicates an imminently hazardous situation that, if not avoided, will result in death or serious injury. Includes hazards that are exposed when guards are removed.



WARNING Indicates a potentially hazardous situation that, if not avoided, could result in serious injury or death. Includes hazards that are exposed when guards are removed.



CAUTION Indicates a potentially hazardous situation that, if not avoided, could result in minor or moderate injury.



IMPORTANT Indicates information about procedures that, if not observed, could result in damage to equipment or corruption to and loss of data.

General Safety



Do not operate or work on this equipment unless this manual has been read and all instructions are understood. Failure to follow the instructions or heed the warnings could result in injury or death. Contact any Rice Lake Weighing Systems dealer for replacement manuals.



Failure to heed could result in serious injury or death.

Take all necessary safety precautions when installing the scale carriage including wearing safety shoes, protective eye wear and using the proper tools.

Ensure feet, legs and other body parts are not under the scale when lowering.

Do not allow minors (children) or inexperienced persons to operate this unit.

Do not operate without all shields and guards in place.

Do not jump on the scale.

Do not use for purposes other than weight taking.

Do not place fingers into slots or possible pinch points.

Do not use any load bearing component that is worn beyond 5% of the original dimension.

Do not use this product if any of the components are cracked.

Do not exceed the rated load limit of the unit.

Do not make alterations or modifications to the unit.

Do not remove or obscure warning labels.

Keep hands, feet and loose clothing away from moving parts.

1.3 Considerations Before Installation

1.3.1 Forklift Derating

Capacity Reduction Calculation

While the CLS will fit most typical forklifts, there are considerations that must be taken into account prior to installation. Due to the extra weight from the scale, the net lifting capacity of the forklift is reduced by approximately 10%. Use the formula below to calculate the amount to down-rate the lifting capacity and determine the net capacity of the forklift.

$$\text{Net Capacity} = \frac{A(B + C) - D(E - F)}{E + G + H}$$

A = Truck Basic Capacity in pounds	B = Inches from front wheel center line to fork face
C = Inches from face to truck rating point (usually 24)	D = Weight of scale in pounds
E = Inches from front wheel center line to carriage face	F = Inches from carriage face to scale horizontal center of gravity (HCG)
G = J + K (inches from carriage face to rear face of load)	H = Inches from fork face to new truck rating point
J = Thickness of fork	K = Thickness of scale

CLS Classes and ID Plates

During the initial sale or installation, remind the customer that they must have an updated ID plate on the forklift stating the new lifting capacity and center of gravity information. This is required per OSHA rules and regulations.

	28 inch	34 inch	38 inch
Vertical enter of gravity (VCG) of scale	= 8.06	8.06	10.15
Horizontal center of gravity (HCG) of scale	= 2.09	2.09	2.83
Effective thickness (ET) of scale	= 4.55	4.55	6.06
Weight of scale	= 392	420	987

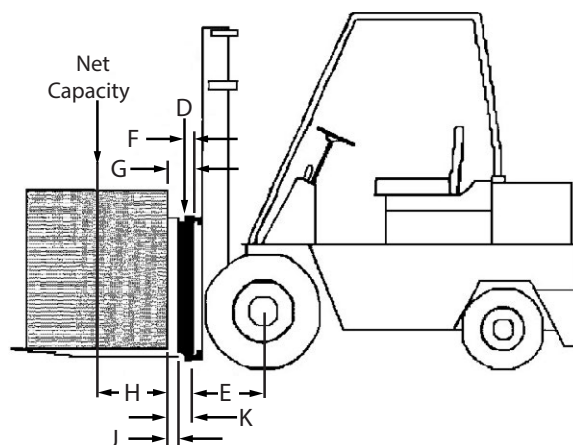
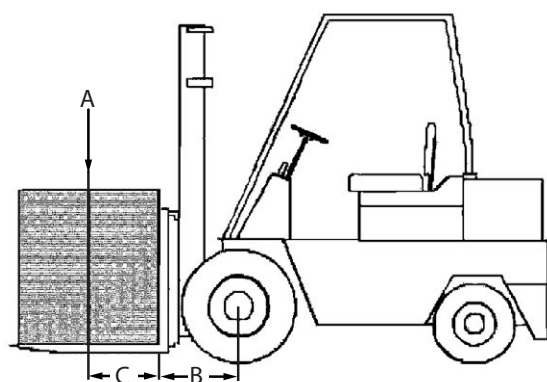

1.4 CLS-IM Junction Box

The latest CLS includes an updated version of the CLS-IM junction box. This design is built to allow service technicians to easily service the unit in the field. It also replaces the older style junction boxes originally used.

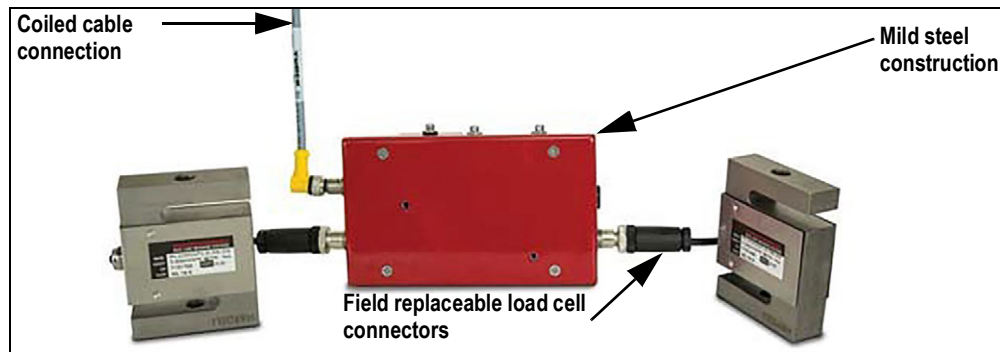

Figure 1-1. CLS-IM Junction Box

2.0 Installation

This section describes procedures for installing the CLS to a forklift.



WARNING

Take all necessary safety precautions when installing the scale carriage, including wearing safety shoes and protective eyewear and using the proper tools which are listed in [Section 2.3 on page 10](#).

2.1 Unpacking

The CLS is shipped upright on a sealed pallet with one or two scales per pallet.

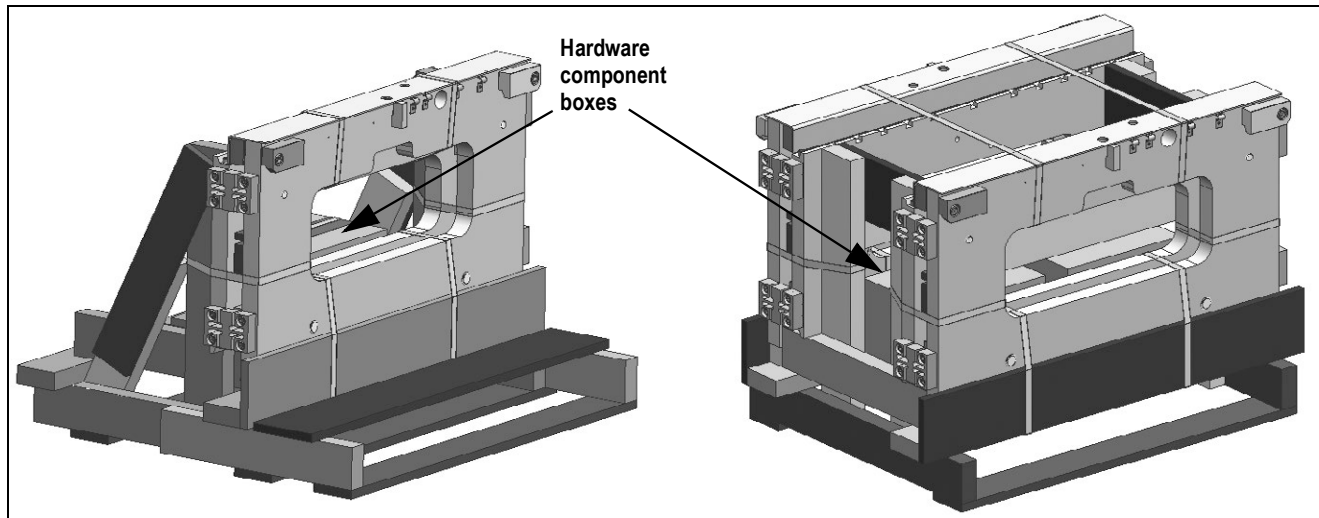

Figure 2-1. CLS Packaging

Upon receipt of the shipping pallet, inspect it for any visible signs of damage. Immediately after unpacking, visually inspect the contents to ensure all components are included and undamaged. The shipping pallet should contain the following:

- One or two scale carriage assembly with cover plate
- Hardware Component Box which includes:
 - Two cleats with four bolts
 - Cage clamp mounting assembly and hardware
 - One coiled interface cable
 - One power cable
 - Feeler gauge



Note

To ensure that all products received from the manufacturer are in good shape upon arrival, it is recommended to fully inspect all contents and properly fill out the bill of lading.

If any parts were damaged in shipment, notify the shipper and Rice Lake Weighing Systems immediately.

The scales are shipped in an upright position, to allow for ease of installation. The accessories are located in a hardware component box.

2.1.1 Unpacking One Scale Configuration

Follow these instructions to unpack one scale.

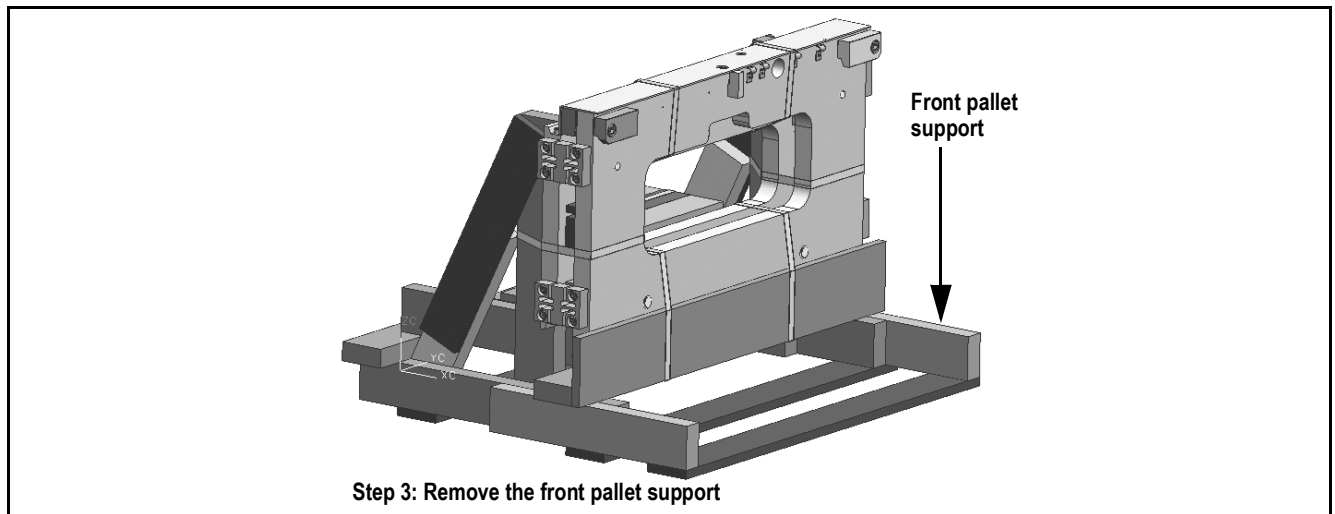
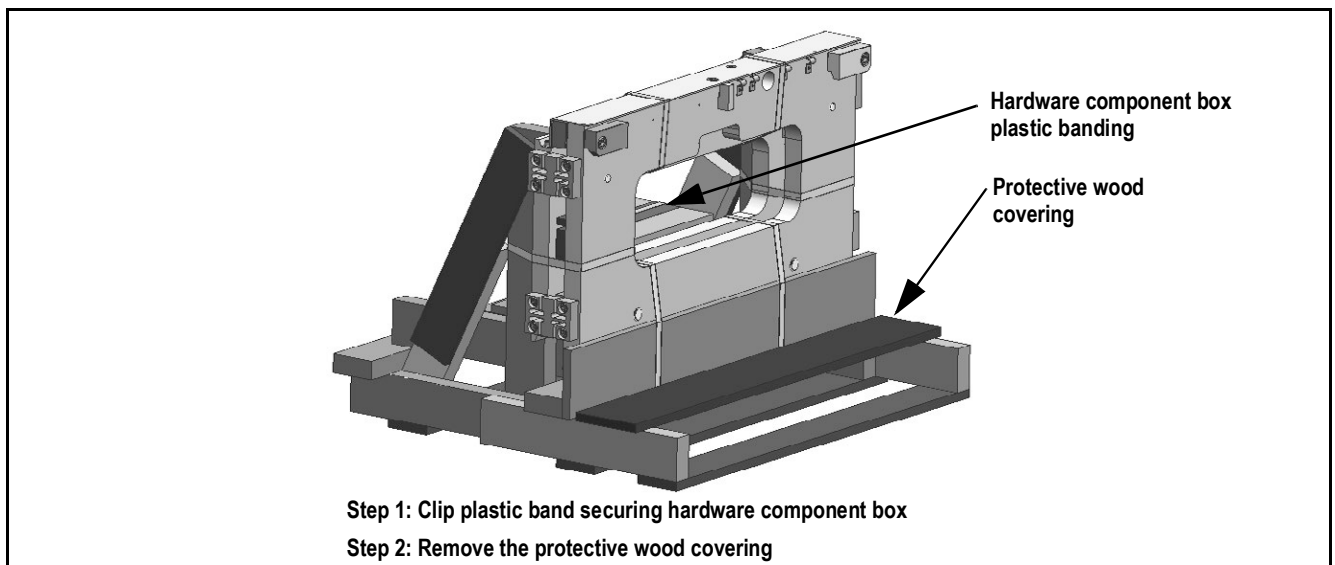
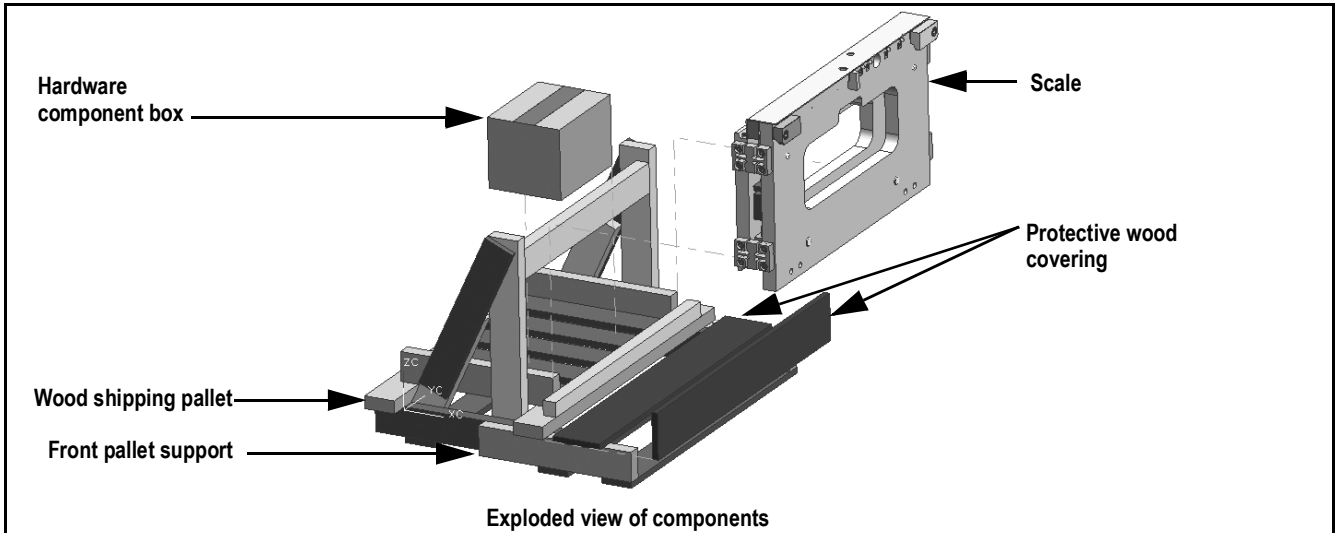

Figure 2-2. Shipping Pallet for One Scale

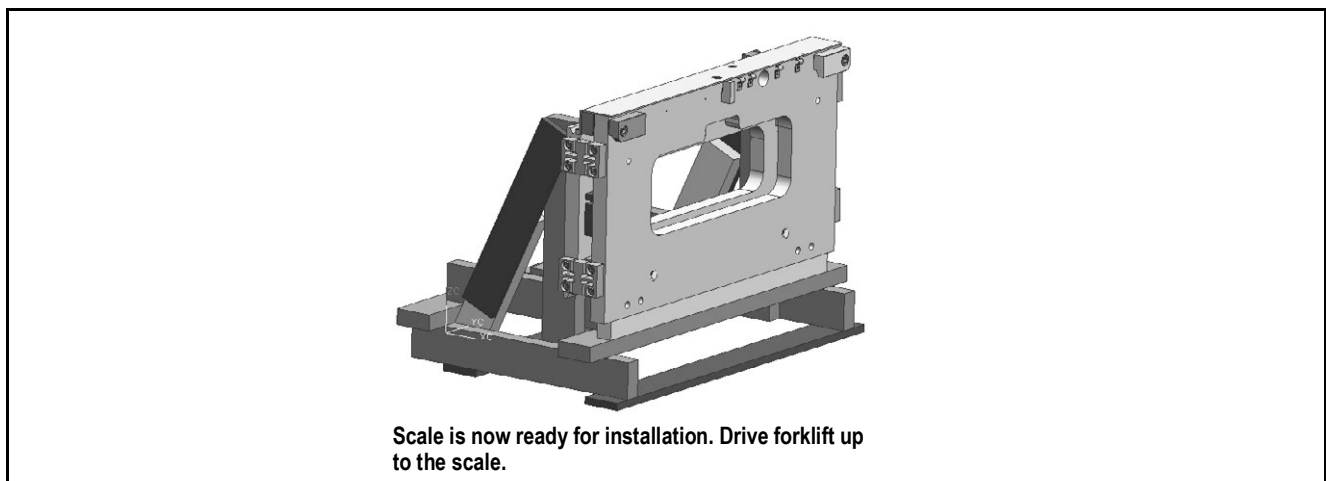
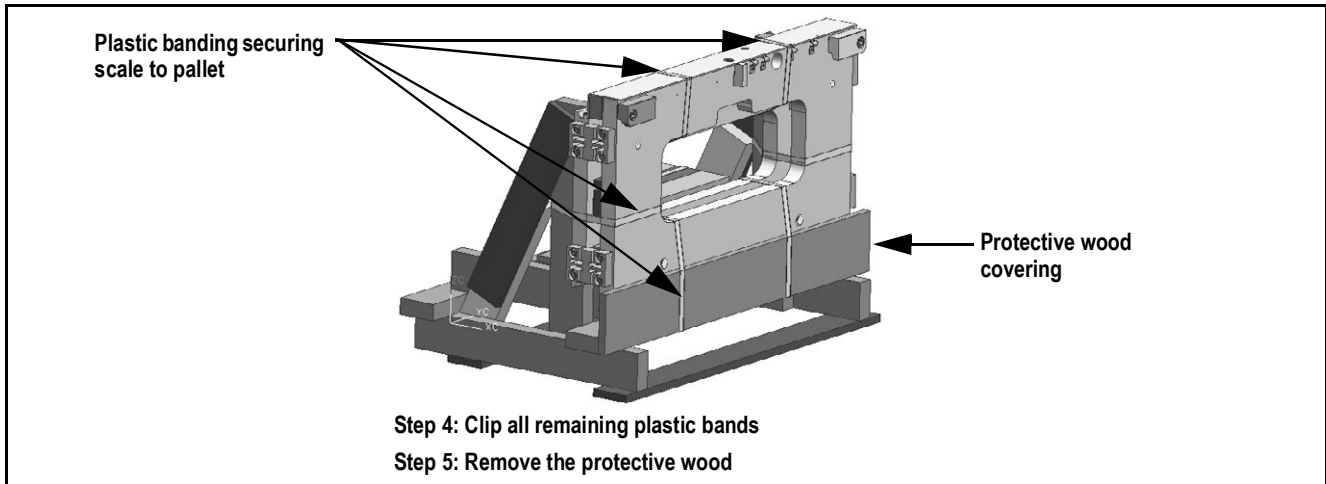

Figure 2-3. Shipping Pallet for One Scale (continued)

2.1.2 Unpacking Two Scale Configuration

Follow these instructions to unpack a two scale configuration.



When installing from a two scale configuration, complete all of steps for scale one before clipping plastic bands securing second scale to the shipping pallet.

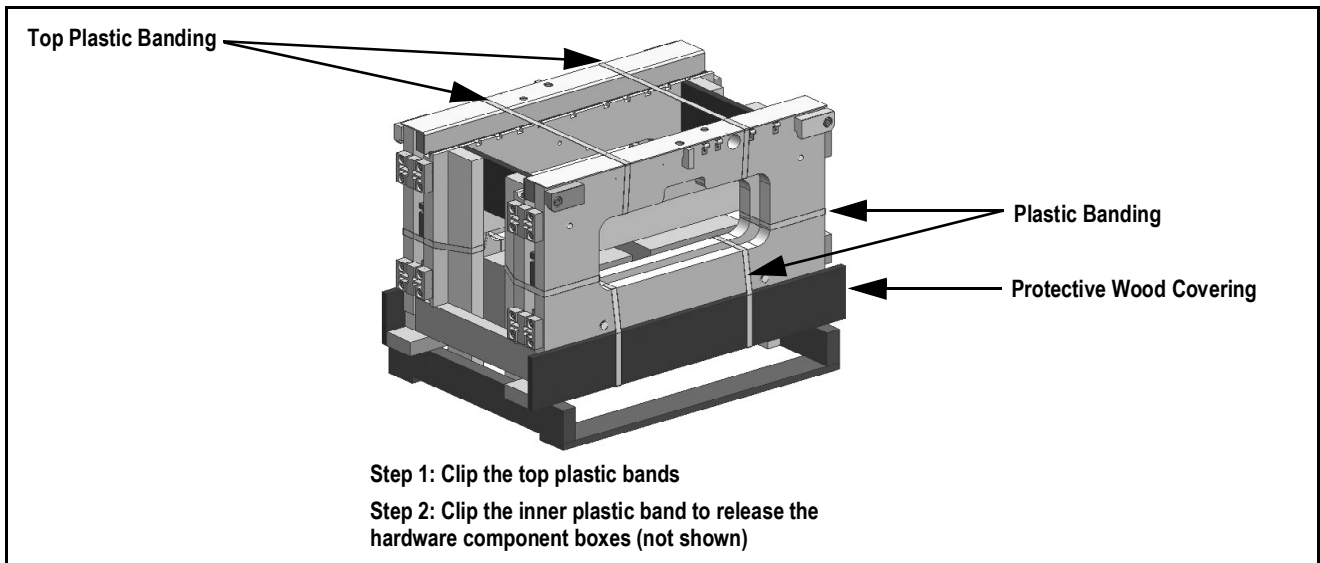
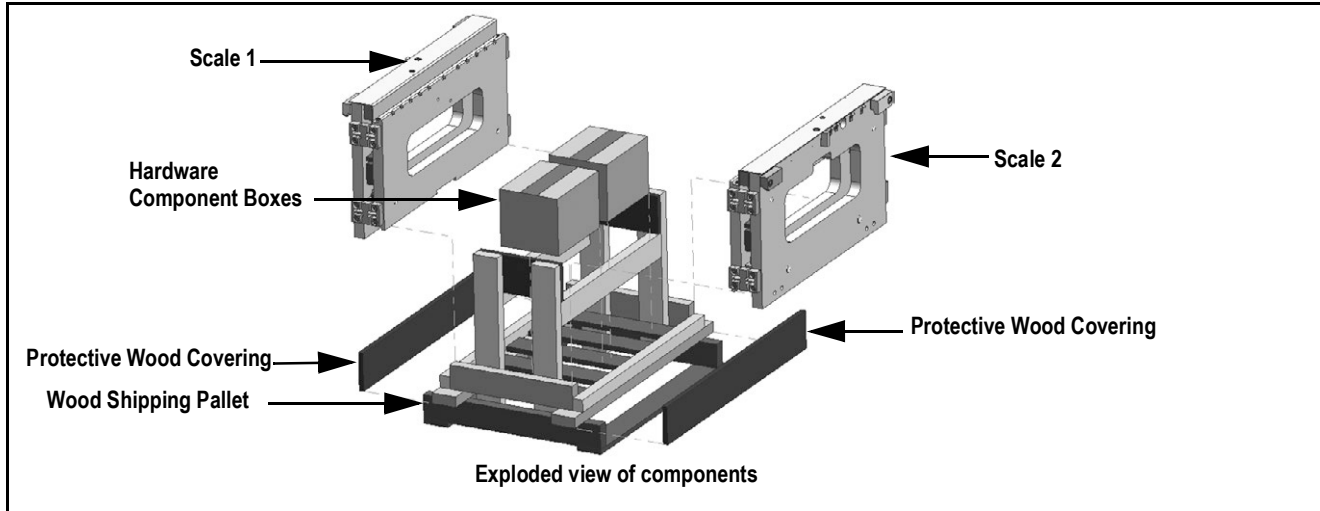

Plastic Banding from Scale 1

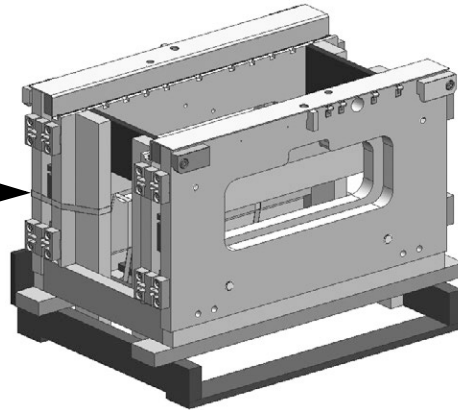

Step 3: Remove hardware component boxes

Step 4: Clip plastic bands from scale #1

Step 5: Remove protective wooden covering from scale 1

Scale 1 is ready for installation

NOTE: Do not clip the plastic band from scale 2 until scale 1 is installed.

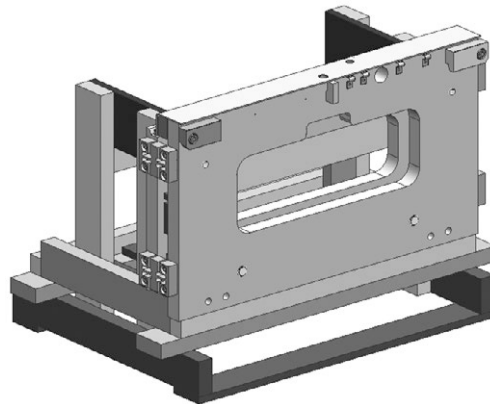

Step 6: Clip the plastic bands from scale 2

Step 7: Remove the protective wood covering from scale 2

Scale 2 is ready for installation

Figure 2-4. Shipping Pallets for Two Scales (continued)

2.2 Before Installation

Before installing the CLS, the forklift should be in good operating condition in order to get optimal weighing accuracy. Review following items prior to installing.

- Inspect the forklift tines for damage
- Check the locking pin on the forks for proper function
- Check and adjust the lift chain so the heel of the forks have 1/2" to 1" of clearance from the floor when the carriage is down and the mast is vertical
- The slot for the center pin should be clear of grease and debris
- The top cleats of the forklift rest on the top of the scale and should remain clear of grease and debris that could alter the scale performance
- The forklift carriage should be flat. A bent or bowed carriage will affect the performance of the scale
- Check the width of the forklift carriage and make sure when the scale is installed the flexures have clearance

The CLS fits most typical forklifts, however, the following considerations must be noted: the height of the carriage, the width of the carriage inside of the guards (if applicable) and the voltage of the forklift.

The optional indicator connects directly to the battery of the forklift. Ensure the type and style of forklift and the type of power it provides is compatible with the indicator. Most propane, gas, and diesel fueled forklifts provide 12 volts of power. Some diesel models also provide 24 volts and electric forklifts provide 36 to 48 volts of power. The CLS has a 9-36 VDC and a 10-60 VDC power supply option. Refer to the forklift user manual for its grounding specifications. The scale will not operate on a positive ground.

IMPORTANT All systems must have a negative ground.

2.3 Tools Required for Installation

The following tools are required to remove the scale from its shipping pallet and install onto the forklift.

Tool	Size	Purpose of Tool
Socket wrench	3/4"	To unbolt the fastening bolts holding the scale to the pallet and to open the top cover plate for wired versions
Allen wrench	1/2"	To bolt and unbolt the bottom cleats of the scale
Wrench - 2" adjustable	1-1/2" 1-5/8"	For adjusting the shim bolts and jam nuts Note: Use a 2" adjustable wrench. Both the shim bolts and jam nuts are painted and a smaller wrench will not fit.
Tin snips or band cutters	--	To cut the metal banding surrounding the CLS on the pallet
Torque wrench w/ 1/2" Allen	1/2"	To tighten the cleats to 125 ft-lb
Electric grinder - if necessary		For grinding the center pin if necessary

Table 2-1. Recommended Tools for Unpacking the CLS

2.4 Scale Base Installation

Use the following steps to install the scale base to the forklift.

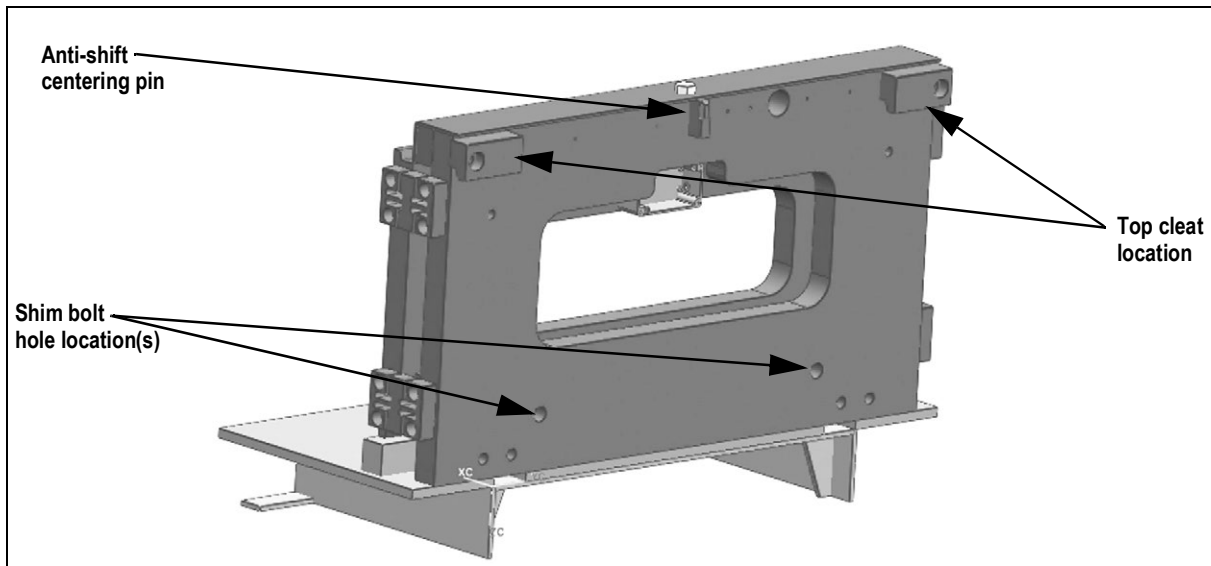

Figure 2-5. Anti-shift Centering Pin, Shim Bolts and Top Cleat Locations

IMPORTANT

Verify that the shim bolts are flush with the back plate of the scale. If they are not flush, the entire scale will be out of alignment when attaching it the forklift. This will make it difficult to make final adjustments once the scale is mounted to the forklift.

1. Make sure the forklift tines are removed and move the forklift in close to the pallet and scale.
2. Ensure the anti-shift centering pin on the scale assembly is aligned with the center notch on the forklift carriage.

IMPORTANT

Consider the following during installation.

- * The scale's centering pin should be aligned with the middle notch of the forklift carriage.
- * Verify that the scale base is adjusted so that the pin is located well within the center notch area of the carriage.
- * The centering pin should not touch the bottom of the notch on the original carriage, as this will cause side to side tilting of the scale.
- * The outside top cleats provide support to the scale assembly and the centering pin only helps to position the scale on the forklift carriage.
- * The centering pin should not bear any weight. If it does, the use of a grinder to grind down the centering pin will be necessary.

3. Tilt the mast forward slightly to catch the scale assembly.
4. Carefully and slowly raise the scale carriage slightly so the top cleats (Figure 2-7) hook onto the forklift carriage. If they do not hook, carefully push the scale toward the forklift as it is being raised.



Ensure fingers and hands are away from the top cleats to avoid pinching and bodily harm.

5. Tilt the mast back to secure the connection and raise the scale to shoulder height.
6. Attach the bottom cleats to the bottom of the scale assembly (Figure 2-8), so the lip of the cleat is behind the scale carriage.
7. Torque the bottom cleat retaining bolts to 125 ft-lb.



Failure to properly torque the bottom plate retaining bolts may result in bodily harm or damage to equipment.

- Using the feeler gauge (included), adjust the shim bolts so there is a minimal clearance between the bottom cleats and the scale carriage of 0.020" thickness.

IMPORTANT

Failure to adjust shim bolts to proper clearance of 0.020 inches may result in binding, poor accuracy or improper fit of attachment to forklift.

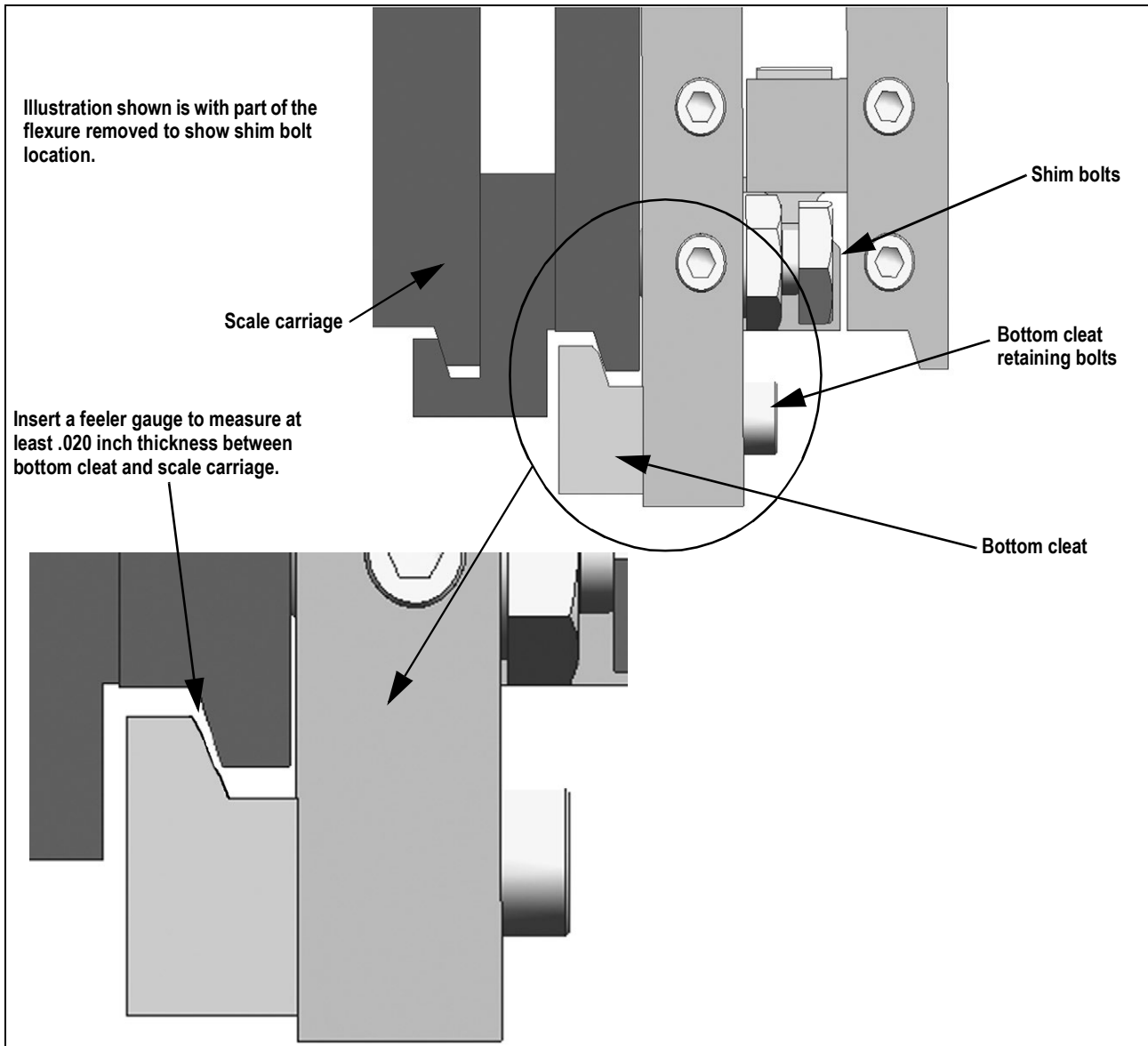

Figure 2-6. Bottom Cleat Location and Assembly

- Upon successful installation and calibration verification, seal the carriage junction box and load cell quick disconnects for Weights and Measurements approval.

2.5 Install Forks

Once the scale is properly installed, the forks need to be installed onto the scale assembly.

1. Align a fork to the center of the scale assembly making sure it is over the top of the assembly.
2. Lift the carriage slightly to set the fork, and then slide the fork to the side of the scale. Let it stop in the 2nd notch from the end and latch it in place.
3. Repeat steps one and two for other fork, sliding it the opposite direction on the scale.



Figure 2-7. Fork Attachment

2.6 Connect Coiled Interface Cable to Junction Box

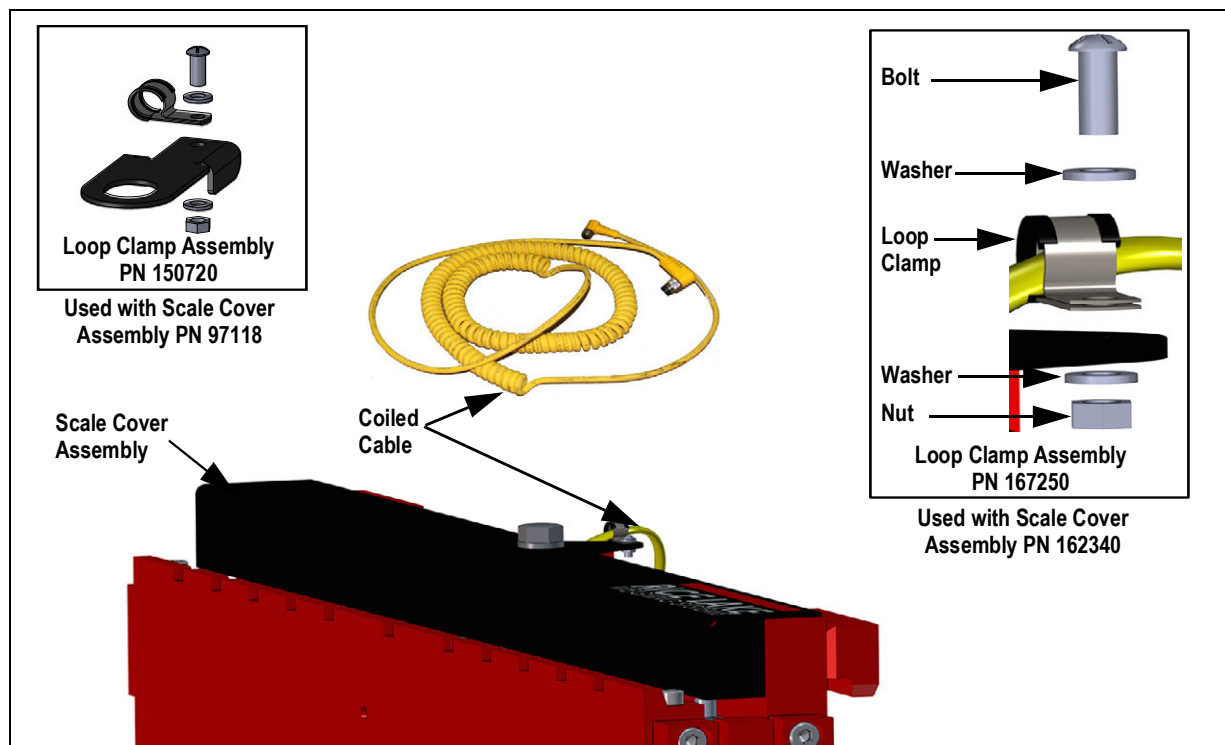

Figure 2-8. Connecting The Coiled Cable

1. Loosen the bolt holding the cover to the scale assembly and remove cover.
2. Assemble loop clamp kit to the coiled interface cable.

3. Route the coiled cable through the clips on backside of carriage toward middle. For proper coiled cable routing, tighten the clips. Set the other end of the cable aside until the power/communication box is installed. See [Section 2.6.1 on page 14](#).
4. Push the coiled interface cable through the hole in the scale and connect it to the junction box.
5. Position the scale cover assembly and the loop clamp assembly to the scale and secure with the bolt and washer.



Note

After successful installation and calibration, replace the cover on the scale assembly and secure with bolt and washer.

2.6.1 Route the Load Cell Coiled Interface Cable



CAUTION

Do not plug the coiled interface cable into the power/communication box until the power hookup is completed.

1. Route the cable connected to the load cell junction box to the indicator from the forklift scale. Routing of the cable varies depending on the forklift style. The preferred route for a single stage forklift is through the center of the mast, up the front/right upright, across the top of the overhead guard and down the rear-right pillar to the power/communication box.

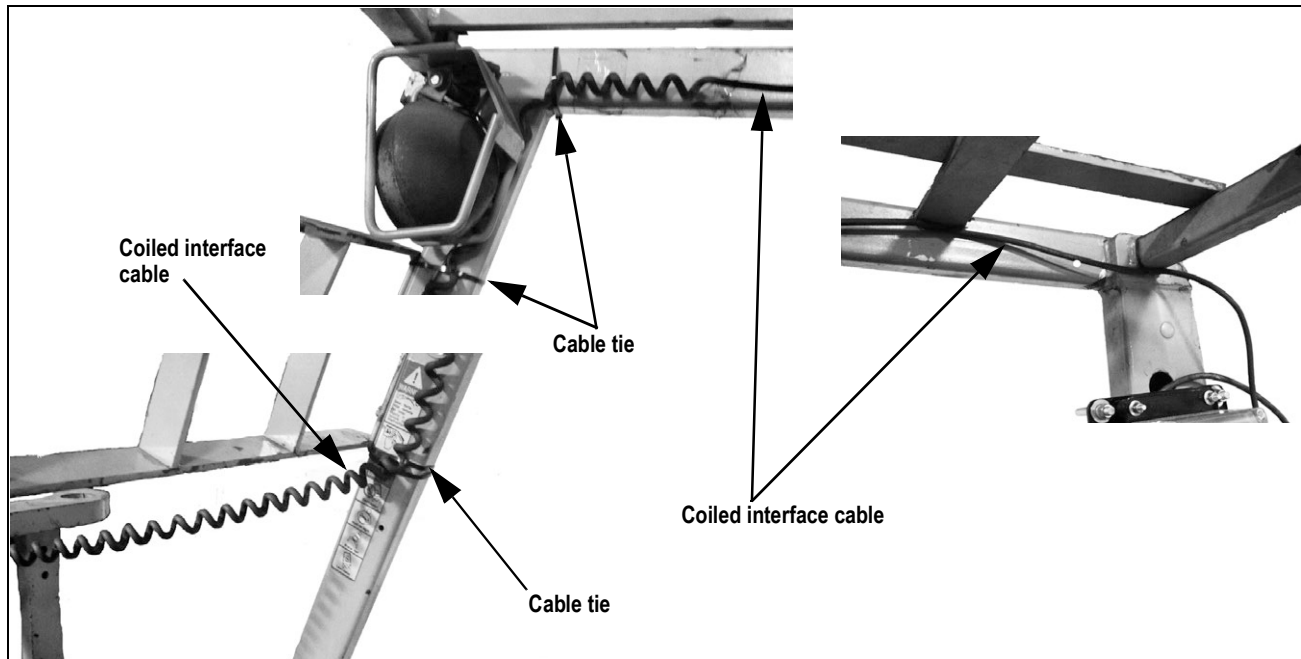

Figure 2-9. Signal Cable Located Between the Scale and the Power/Communication Box

2. Secure with cable ties at the scale, at the top of the mast and several other locations to keep it securely in place.
3. Slowly and carefully extend the mast to all positions to confirm that the cable isn't pulled too tight and that there are no pinch points along the cable route.
4. Check for proper signal cable clearance as the side shifter (if used), is moved back and forth.
5. After the power hook-up is completed, plug the power connector into the power/communication box.



Note

Do not obstruct the view of OSHA labels on the forklift when routing cables.

3.0 Parts and Service

3.1 Daily Inspection Checklist

- Check scale carriage for loose, worn, bent or broken components.
- Inspect fork tines for damage.
- Check locking pins on fork tines.
- Inspect coiled cable for pinched, rubbed, stretched or damaged areas.
- Inspect power cable from indicator to battery for nicks or cuts.
- Make sure power cable is routed out of harms way, fasten periodically to eliminate potential problems.
- Tighten cable connections at indicator junction box if necessary.
- Inspect coiled cable clamps and cable ties to ensure all cable attachments are secure.
- Inspect indicator mounting bracket, isolation mounts and hardware for loose or cracked parts.
- Tighten bottom clamps on scale carriage if necessary. Raise carriage and visually inspect.
- Check and adjust the lift chain so the heel of the forks have 1/2" to 1" of clearance from floor when the carriage is down and the mast is vertical.

3.2 Cargo Lift Scale Assembly

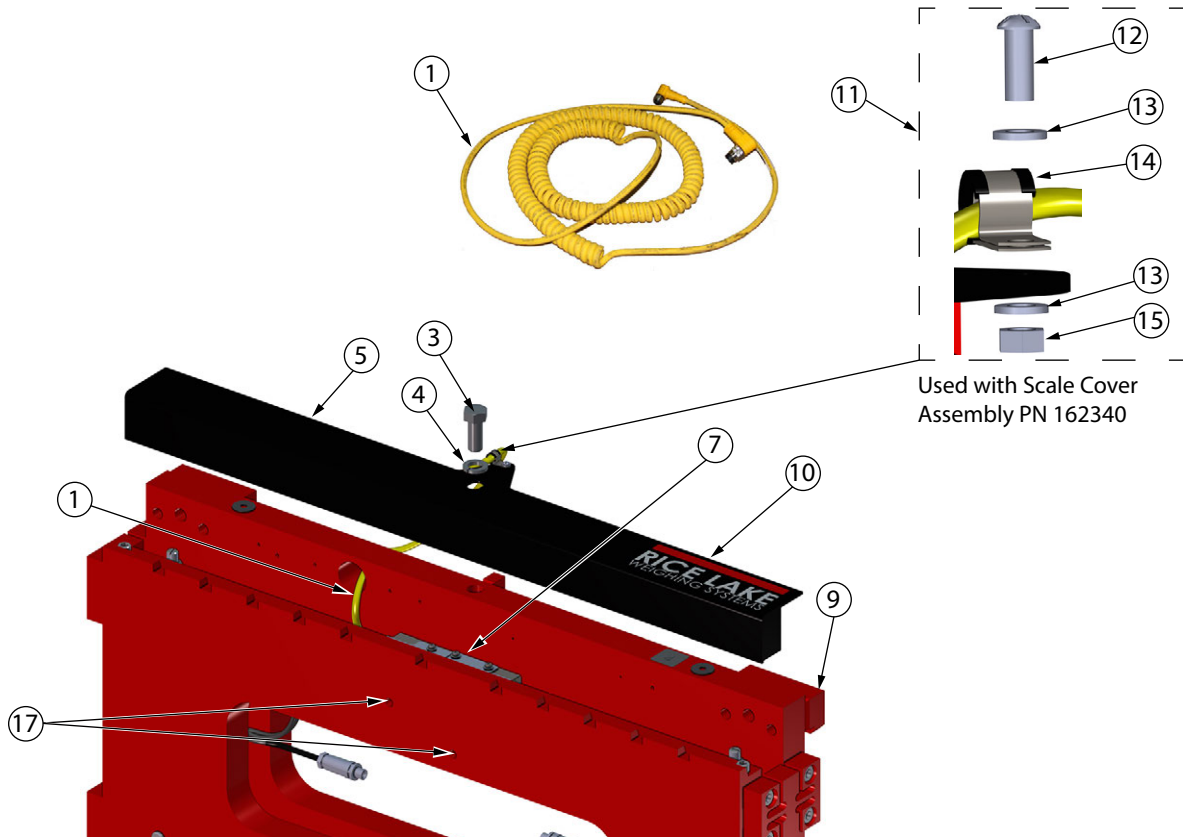

Figure 3-1. Cargo Lift Scale Assembly Parts Illustration

Item No.	Part No.	Description	Qty
1	125395	Cable Assembly, Coiled 5x18AWG	1
3	127009	Screw, Cap 5/8-11NC	1
4	111731	Washer, Lock 5/8 Regular	1
5	162340	Angle, Protective, 34"	1
9	191641	Scale, Cargo Lift, 34"	1
11	167250	Kit, Loop Clamp, Coiled Cable Assembly (Inc 12-15)	1
12	126980	Screw Machine 10-32 x 1/2	1
13	15141	Washer, Plain STD No 10	2
14	150719	Clamp, Loop One Hole 1/4"	1
15	14633	Nut, Lock 10-32NF Hex	1
17	125649	Hex Socket Cap Screw 10-32 x 1 SST	2
NS	126770	Bottom Cleat, 34" and 28"	2
	92810	Screw, Cap	4
NS	53308	Label, 1.25 x 1.25 8000T	2

Table 3-1. Cargo Lift Scale Assembly Parts List

3.2.1 Load Cell Assembly

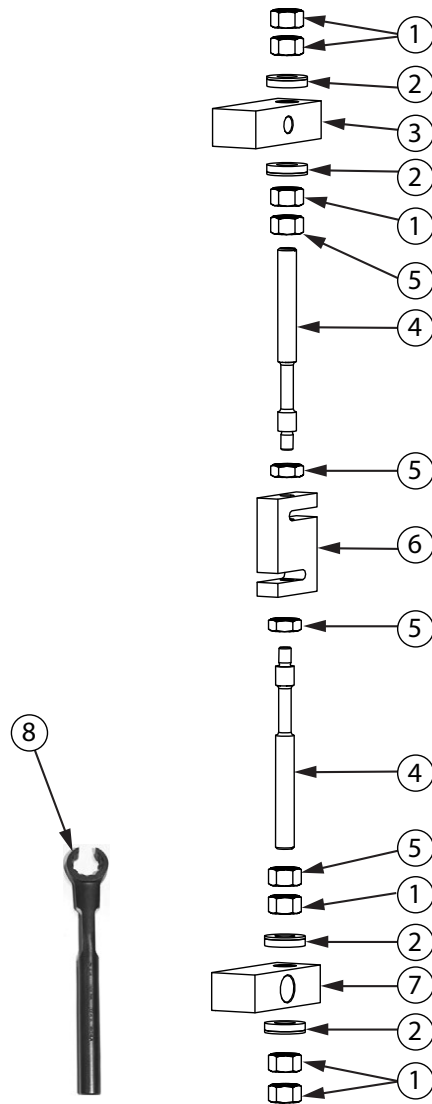

Figure 3-2. Load Cell Replacement Kit Parts Illustration

Item No.	Part No.	Description	Qty
	97883	Load Cell Replacement kit (inc items 1, 2, 4, 5, 6 & 8)	Ref
1	109958	Hex Nut	6
2	15198	Spherical Washer Set	4
3	--	Upper Block	Ref
4	92827	Flexure Rod	2
5	14665	Jam Nut	4
6	166623	Load Cell with Turk Connectors	1
7	--	Lower Block	Ref
8	96196	Wrench, Box Load Cell	1

Table 3-2. Load Cell Replacement Kit Parts List

3.2.2 CLS-IM Junction Box Assembly (PN 191642)

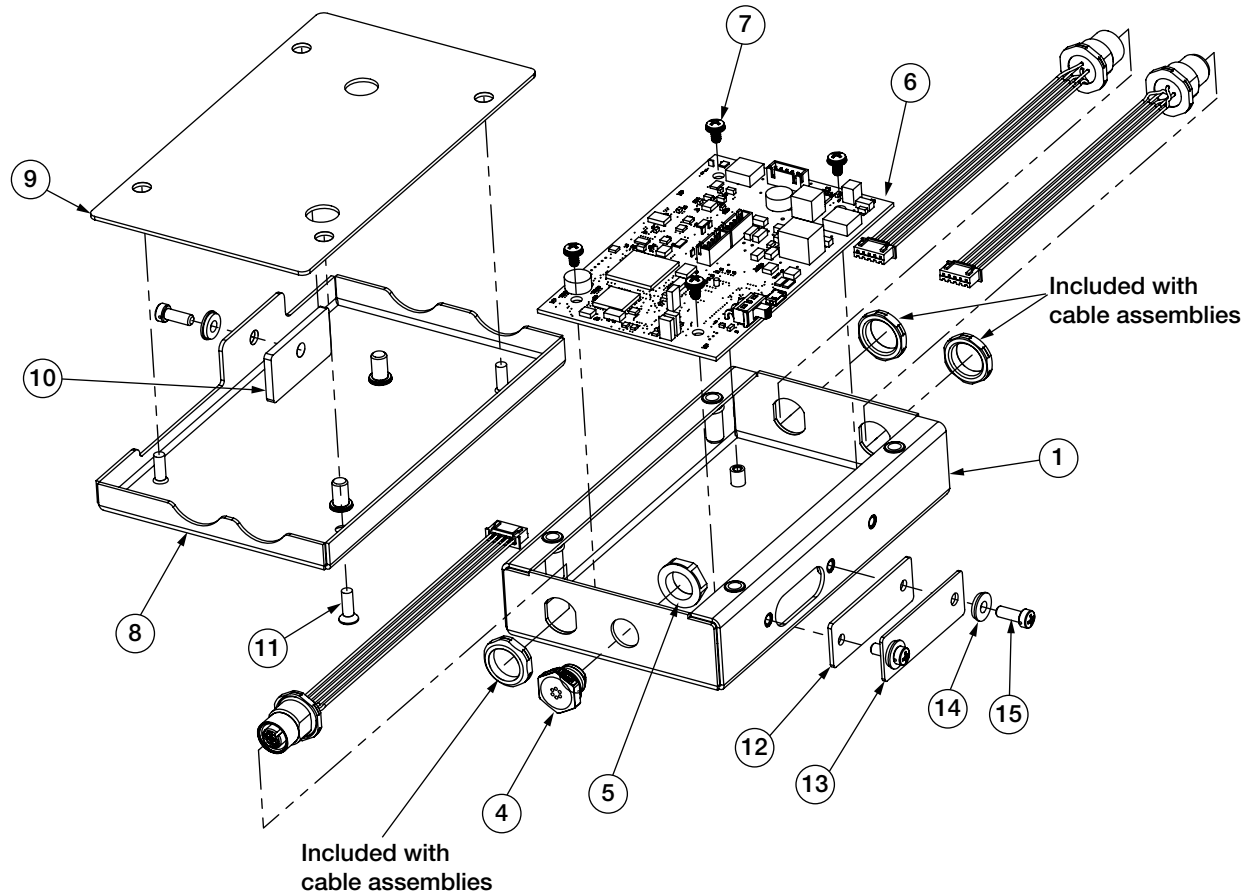

Figure 3-3. CLS-IM Junction Box Assembly (PN 191642)

Item No.	Part No.	Item Description	Qty.
1	191660	Enclosure Assembly	1
4	164598	Breather Vent	1
5	88734	Nut, Breather Vent Thread	1
6	191673	Junction Box PCB Assembly	1
7	14839	Screw, 6-32NC x 1/4	4
8	191659	Cover Assembly	1
9	163764	Gasket, Assembly Cover	1
10	164070	Gasket, Access Cover	1
11	100968	CR-FHMS 0.164-32 x 0.5 x 0.5-N-SST	4
12	163765	Gasket, Access Cover	1
13	162384	Cover Plate, Access Hole	1
14	75062	Sealing Washer, #8	3
15	30623	Screw, 8-32NC x 7/16	3
16	52342	Label	1

Table 3-3. CLS-IM Junction Box Assembly (PN 191642)

3.3 CLS-IM Junction Box Maintenance/Upgrade

The CLS-IM junction box is designed for use with the Rice Lake's CLS forklift scales.

3.3.1 CLS-IM Replacement

The junction box is located between the front and back panels of the scale and is covered by the metal cover plate on the top of the scale.

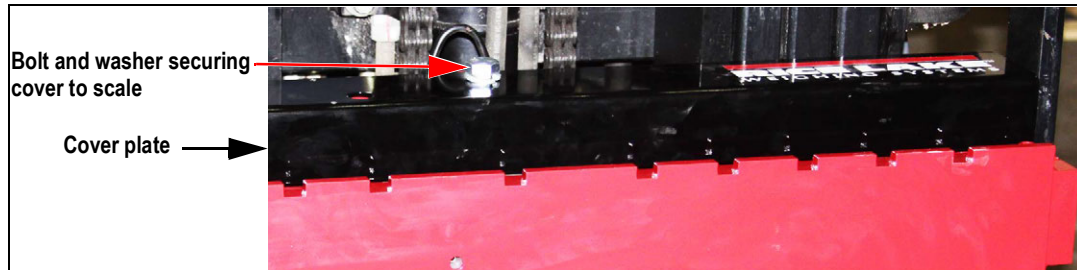

Figure 3-4. Remove Cover Plate

1. Turn scale power off on the indicator.
2. Remove the bolt holding the cover plate in place.
3. Remove the cover plate and set aside.
4. Unplug the power cable.
5. Lift the forklift to a comfortable working height.
6. Use a #4 metric Allen wrench, remove the two screws securing the junction box to the scale.
7. Remove the coiled interface cable from the junction box.
8. Disconnect the load cell cables.

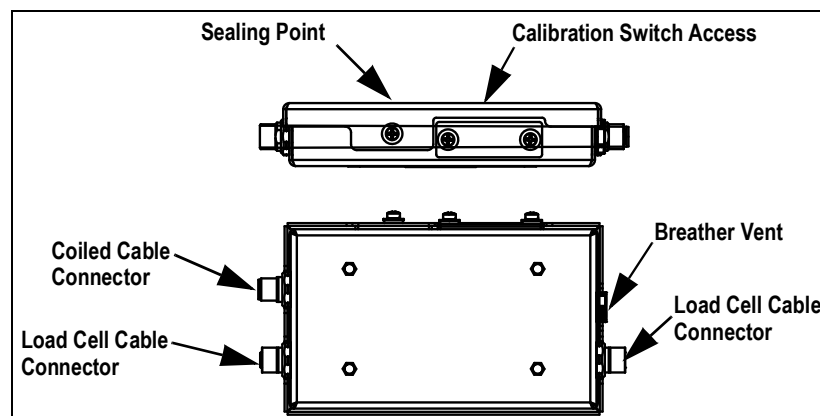

Figure 3-5. CLS-IM Junction Box

9. Attach the load cell cables to the bottom two connectors on the junction box.
 - Apply Loctite.
 - Hand tighten until the connection is snug, plus another 1/4 turn. Only two threads should be visible.

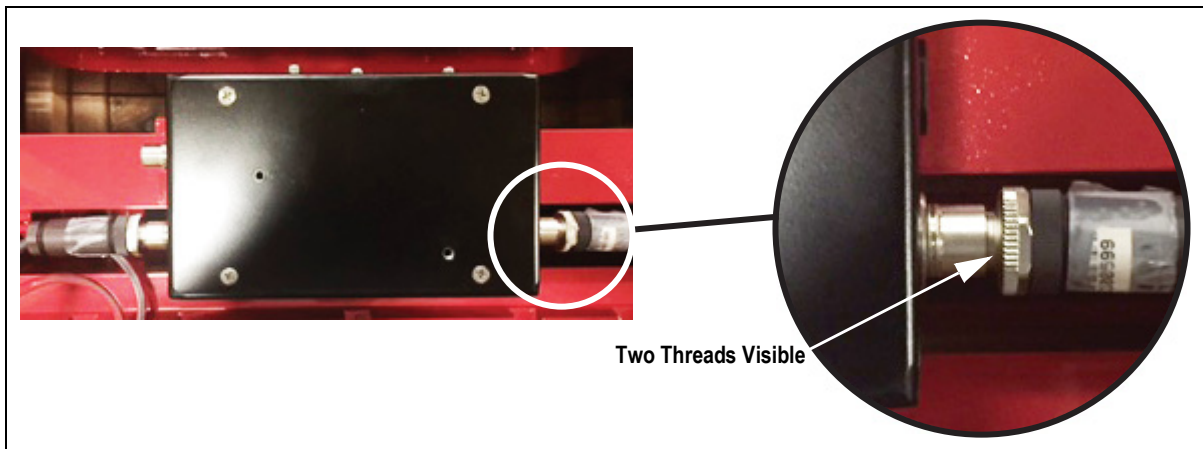

Figure 3-6. Connect Load Cell Cable to Junction Box

10. Connect the load cell cables to each side.
11. Connect the coiled interface cable to the top of the junction box.
12. Align the CLS-IM junction box with the bolt holes in the scale and use an Allen wrench to tighten.
13. Place the cover plate in place and secure with a bolt and washer, and seal the unit.

3.3.2 CLS-IM PCB Board Assembly Replacement

1. Remove junction box from the scale carriage. See [Section 3.4.1 on page 31](#).
2. Loosen four screws to remove front cover of junction box.
3. Disconnect connectors for load cells and coiled cable.
4. Remove PCB board assembly.
5. Install new PCB board assembly and install screws using blue Loctite.
6. Install connector for load cell and cable.
7. Replace cover and secure with four screws, Loctite not required.

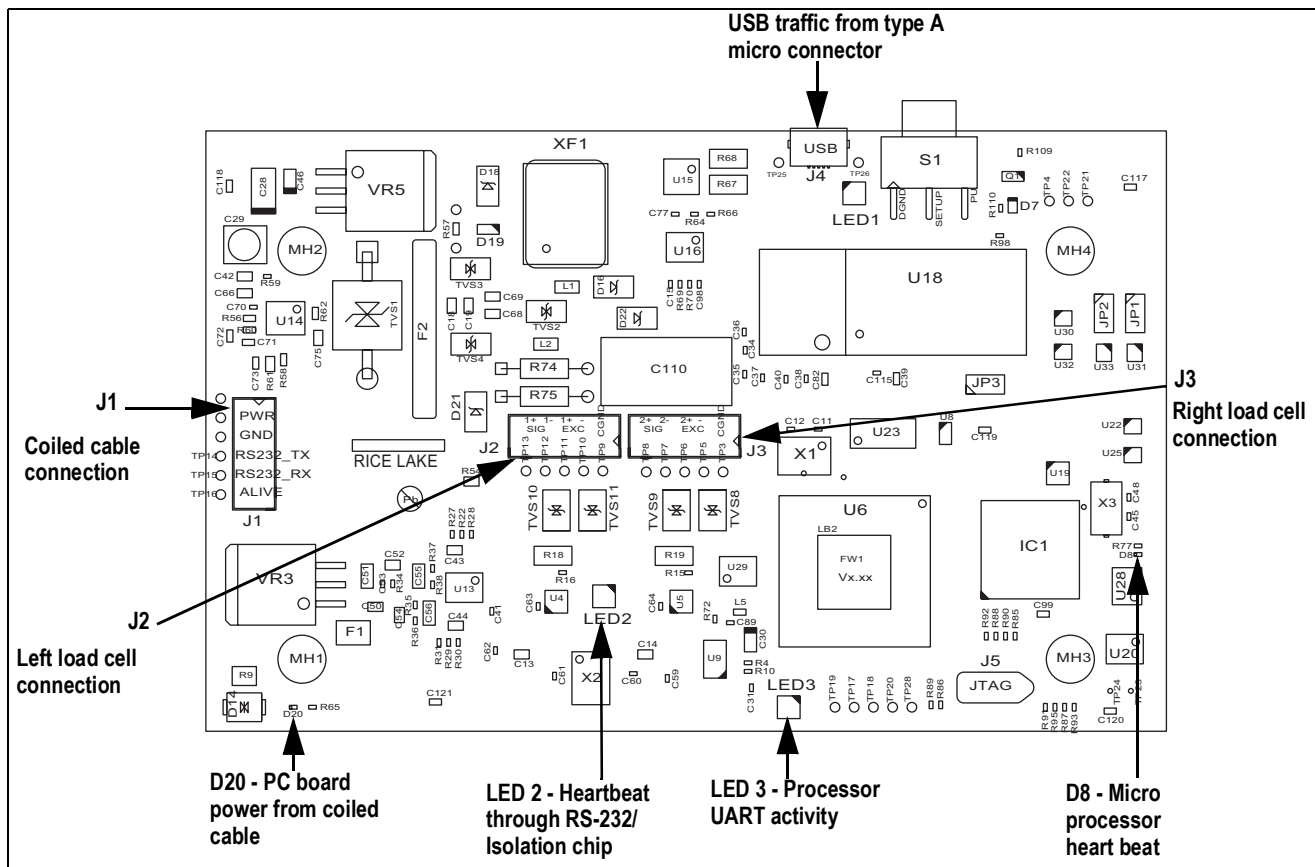

Figure 3-7. Troubleshooting iQube2 PCB Assembly LEDs (PN 162508)

3.4 Load Cell Maintenance

This section describes procedures for replacing a load cell. The CLS uses Rice Lake's load cell, PN 125543.

The following instructions must be followed exactly to allow for seamless and easy load cell replacement.



WARNING

Take all necessary safety precautions when installing or replacing the scale parts including wearing safety shoes, protective eye wear, and using the proper tools.

3.4.1 Required Tools for Replacing a Load Cell

The following list of tools is required for replacing a load cell on the CLS.

- Modified box wrench (PN 96196 - supplied with load cell replacement kit)
- Crescent wrench
- 3/4" socket wrench, with extensions
- Ball-peen hammer
- 1 1/8" wrench for overload stop
- Chisel
- Allen wrench for overload stops
- Torque wrench
- Pry bar



Note

Adequate light is necessary to change the load cell. Position the forklift close to a good source of natural light, or have a good source of lighting available.

3.4.2 Load Cell Replacement

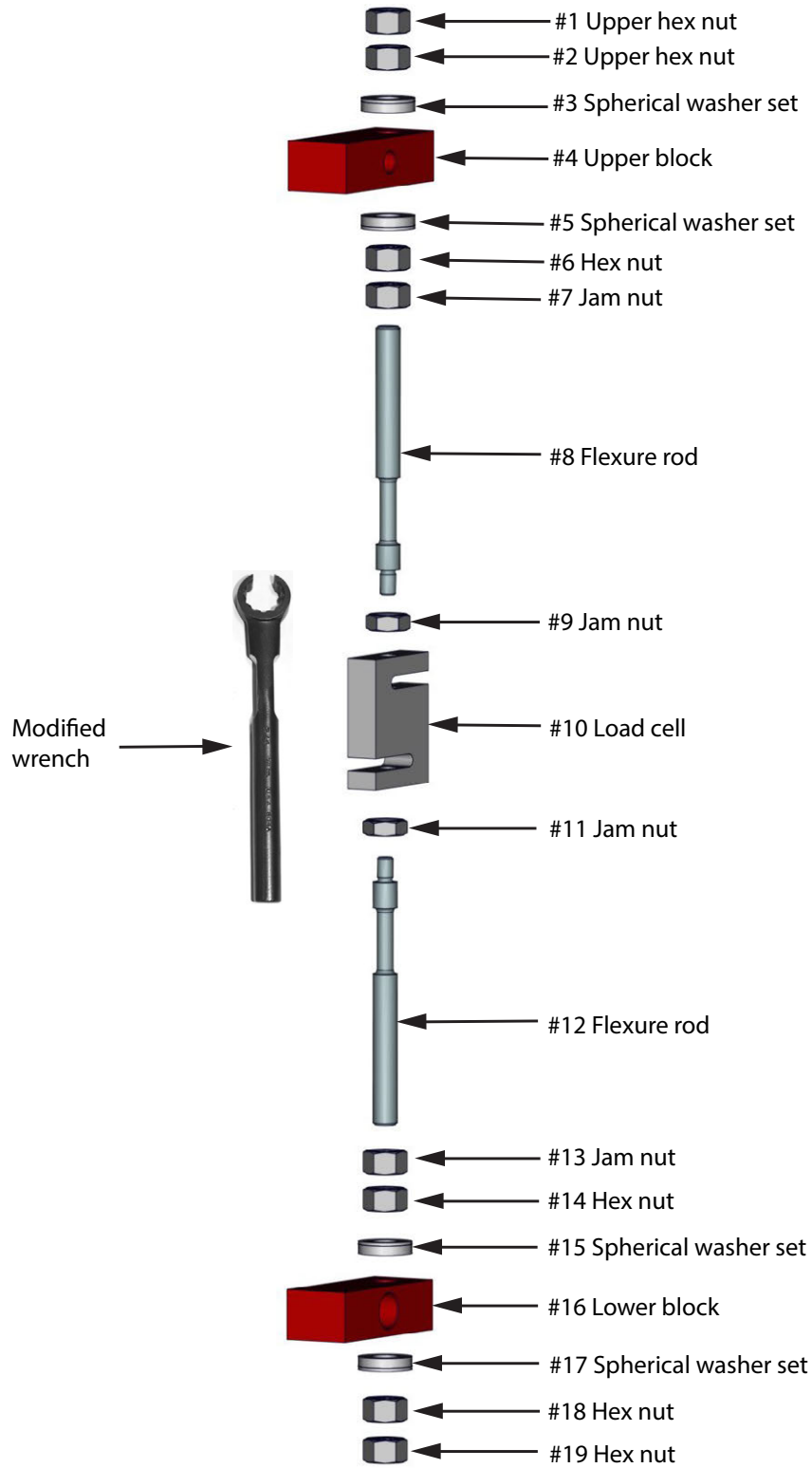

Figure 3-8. CLS Load Cell Assembly Parts Breakout

Use the following steps to replace a load cell.

1. Raise the forklift carriage slightly for fork removal.
2. Slide the forks to the center of the carriage to allow for removal. Set forks aside.

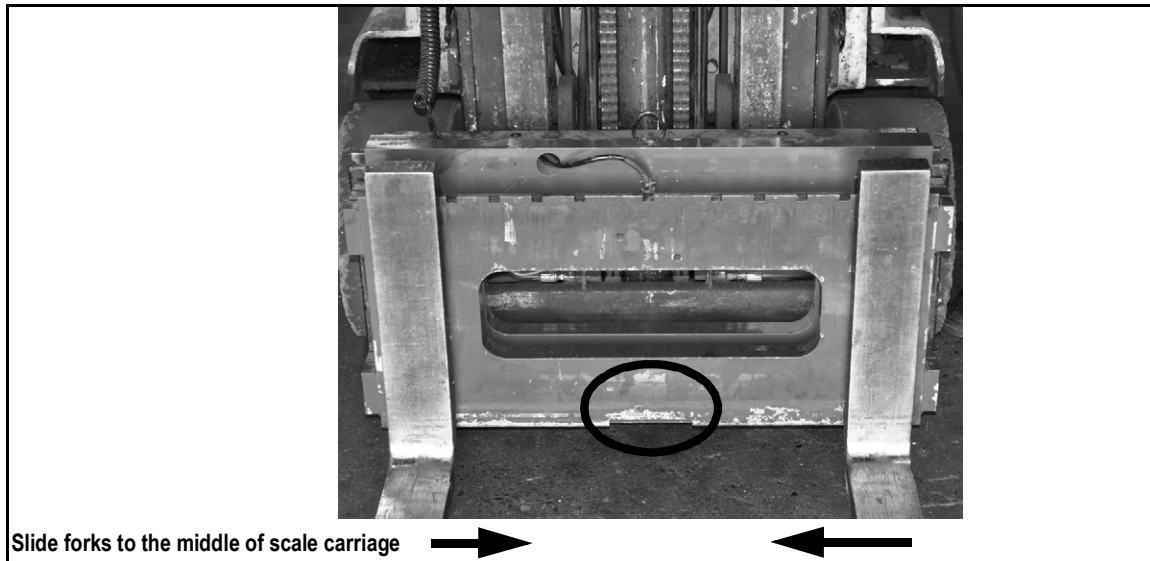

Figure 3-9. Fork Removal

3. Raise the forklift carriage to a comfortable working height for the load cell replacement.
4. Remove the top hex nut (#1) with a socket wrench.



Note *It is acceptable if the load cell slightly rotates up against the front or back plate of the scale.*



Figure 3-10. Remove Hex Nut

5. Loosen jam nut (#7) from the upper block using the special modified box wrench (PN 96196 - supplied with load cell replacement kit) and shown in [Figure 3-8](#).
6. Loosen jam nut (#13) from the lower block.
7. Remove the top hex nut (#2) and the top spherical washer set (#3).

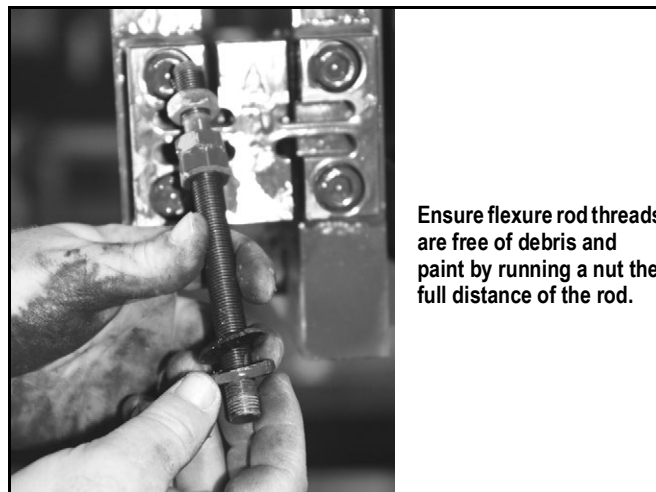

Figure 3-11. Remove Bottom Nut



Note *It is acceptable if the load cell slightly rotates up against the front or back plate of the scale.*

8. Remove the bottom hex nuts (#18 and #19) and the bottom spherical washer set (#17).
9. Loosen the hex nut located under the upper block (#6).
10. Loosen the jam nut located on top of the load cell (#9).
11. Loosen the hex nut (#14) located on top of the lower block.
12. Loosen the hex nut (#11) on the lower side of the load cell.
13. Remove the bottom flexure rod (#12) and the top flexure rod (#8) sliding remaining washer sets (#5 and #15) with it.



Ensure flexure rod threads are free of debris and paint by running a nut the full distance of the rod.

Figure 3-12. Remove Flexure Rod with Nuts and Washers

14. Check the flexure rod threads for smooth operation by running a nut the full distance of the rod, making sure it does not get stuck anywhere along the way. Clean off any paint using a wire brush and oil.
15. Oil the spherical washers using a standard machine shop oil.
16. Disconnect the load cell cable from the junction box.
17. Loosen cable clips and remove the load cell.

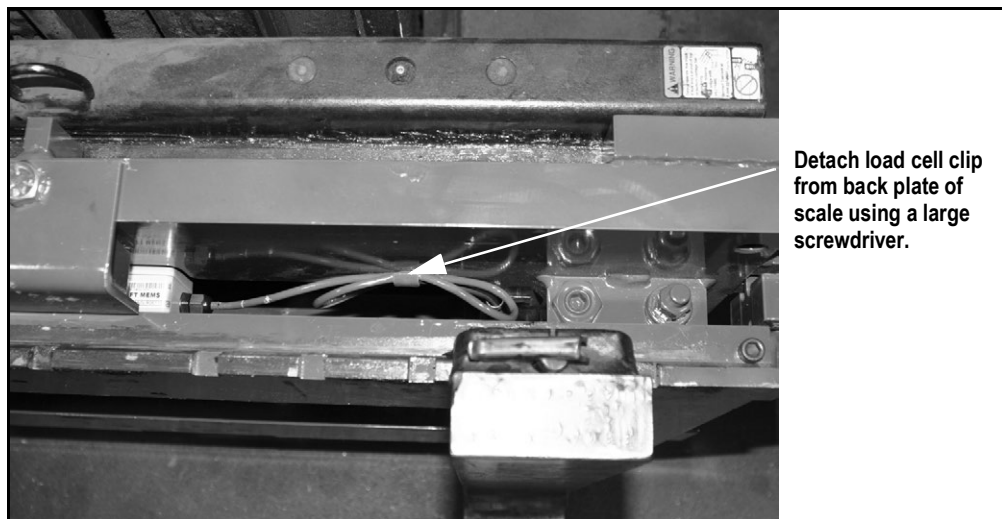

Figure 3-13. Load Cell Cable Clips

18. Back off upper and lower overload stops using a 1 1/8" wrench.

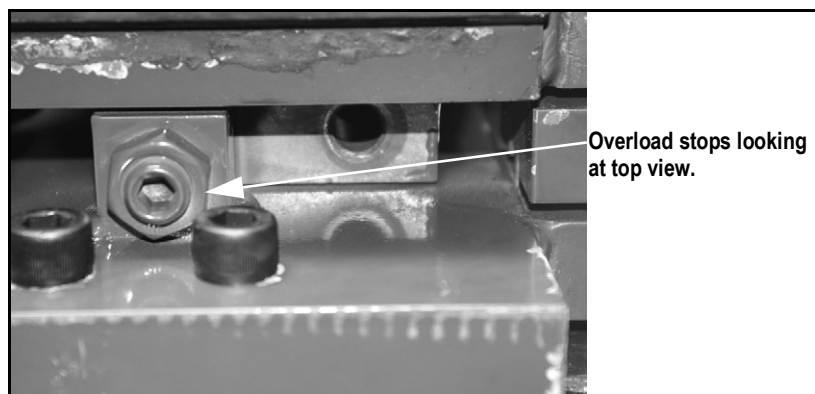

Figure 3-14. Overload Stops

19. Position a new load cell with its cable facing towards the center and opening of the S-beam facing the flexure.

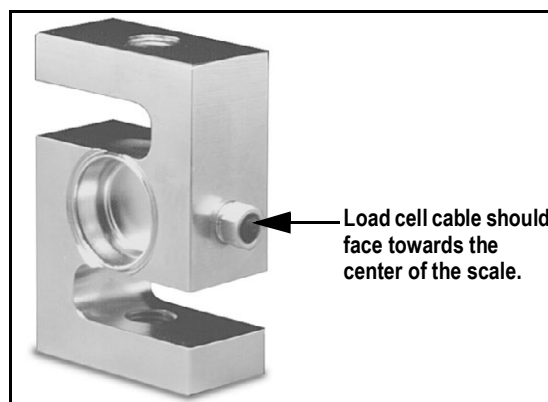

Figure 3-15. Load Cell

20. Install the top and bottom flexure rod with hardware, ensuring that the flexure rod is oriented with the short thread of the rod facing nearest the load cell.

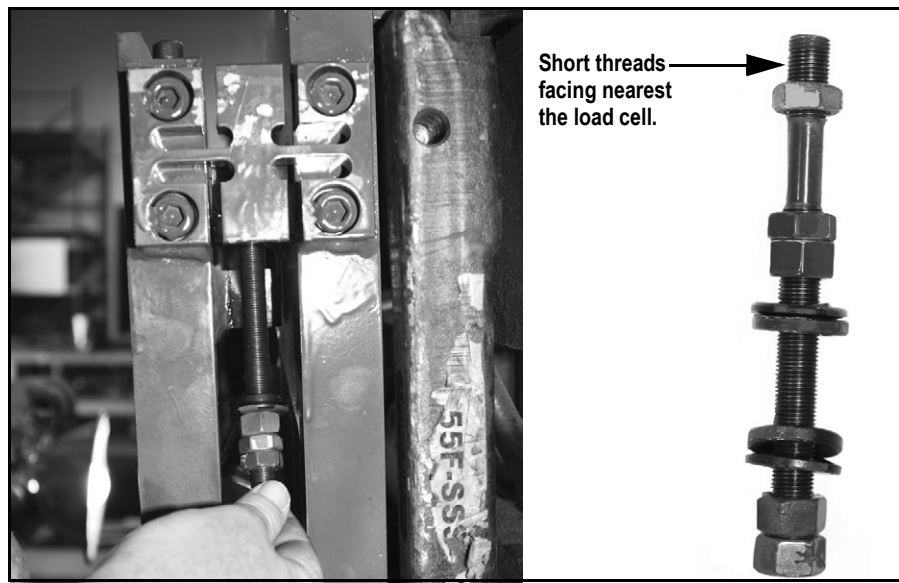

Figure 3-16. Installing Flexure

21. Insert the load cell and thread flexure rods into top and bottom of the load cell making sure the appropriate hex nuts, jam nuts, and spherical washers are in the correct order per [Figure 3-8 on page 22](#).
22. Screw in the rod and tighten jam nut leaving approximately two threads exposed outside of the jam nut. Do both the top and bottom of the load cell.
23. Use hex nuts to position the load cell in the center of the mounting blocks with an equal amount of flexure rod on the top and bottom of the load cell.
24. Tighten the jam nuts on the top and bottom of the load cell, making sure they are tight, and load cell is completely vertical with the scale. Use a pry bar or chisel to hold the load cell straight.

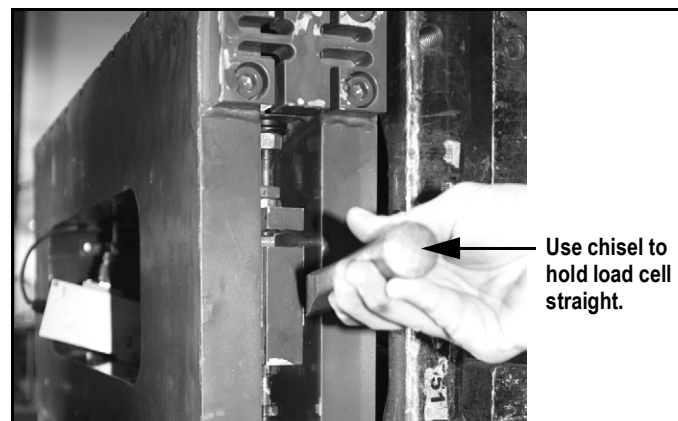

Figure 3-17. Use Chisel to Hold Load Cell Straight

25. Install the spherical washer set and hex nut on the bottom flexure rod, ensuring that the thick washer is mounted towards the mounting block.



Figure 3-18. Install Spherical Washer Set

26. Insert a flat-bladed screwdriver in the upper mounting block between the hole and the flexure rod, forcing the flexure rod in the same direction of the flexure.

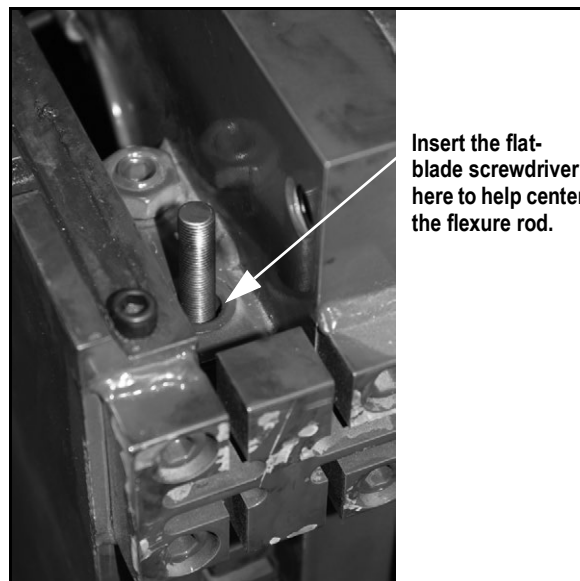

Insert the flat-blade screwdriver here to help center the flexure rod.

Figure 3-19. Centering the Flexure Rod

27. Use a pry bar or chisel to hold the bottom half of the load cell straight while using a torque wrench to tighten the bottom hex nut on the lower mounting block to 110 ft-lb. Install the other hex nut on the bottom of the flexure rod and torque it to 110 ft-lb.



Figure 3-20. Center Load Cell



Figure 3-21. Tighten Lower Nut

28. Use the special modified box wrench to tighten the jam nut (#13) on the lower block.
29. Remove the flat-bladed screwdriver used in Step 25 and inspect the flexure rod. The flexure rod must be in the center of the hole. If it is not, use a hammer and an angled diamond chisel to hit the bottom mounting plate and spherical washer set to adjust it to center.
30. Install the spherical washer set (#3) and hex nut (#2) on the top of the upper block.
31. Connect the load cell cable to the junction box.
32. Torque the hex nut (#2) on the upper mounting block until 100 lb is displayed on the indicator. Tighten the lower hex nut (#6) below the upper mounting block using the modified box wrench and get the display as close to zero as possible.
33. Torque the top hex nut (#1) with a torque wrench to 110 ft-lb. Use a pry bar or chisel to ensure the load cell stays centered while tightening and doesn't touch the sides of front or back panel.
34. Install the final hex nut on the top mounting plate and torque to 110 ft-lb. Use a pry bar or chisel to keep the load cell centered.
35. Tighten the jam nut on the lower mounting block assembly.
36. Exercise the scale, heel to toe, by placing a weight (1000 lb) on the heel, then the toe to check if the assembly was installed correctly. Do this for both sides. If the weight is off, check assemblies.
37. Place a weight in the center of the fork and check side to side values. The weight values must be equal to complete the load cell replacement.
38. Tighten the overload stops when complete.
39. Calibrate the load cells (See [Section 2.3 on page 11](#)).

3.4.3 Forklift Flexure Troubleshooting

For Part Number 92828

The forklift flexure is designed to protect the load cell from damage in the forklift environment.

Use the following steps if the forklift scale is out of tolerance or unable to return to zero on a consistent basis.

1. Check for debris within the scale or between the scale carriage.
2. Check for proper spacing of the jam nuts at 0.02".
3. Check the dimensions of the flexure for damage. There should be a ± 0.03 " tolerance to the drawing shown below for height and width.

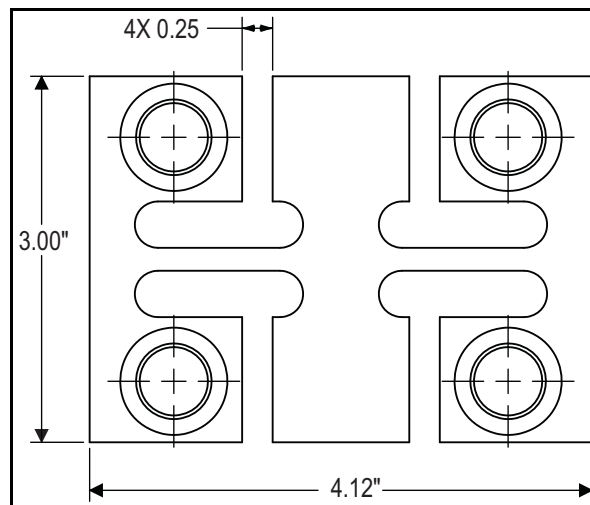

Figure 3-22. Flexure Chassis

4.0 Troubleshooting

4.1 Troubleshooting Chart

Symptom	Possible Cause	Action	
Scale reading high against test weight	Debris between the scale and the forklift carriage	Remove debris	
	Debris between the front and back scale plates	Remove debris	
	Centering pin touching the forklift carriage, causing it to teeter back and forth	Adjust scale carriage, centering pin should not touch on sides and bottom	
	Bottom cleats not adjusted properly or loose	Adjust to proper gap using jam nuts, 0.02"	
	If all of these steps do not resolve the issue, check the following		
	Junction box error	Open junction box and look for obvious damage	
	Load cell errors	Test mV/v levels, at 1.5 mV per 1,000 lb, test at 350 ohms	
Scale reading low against test weight	Zero key has been pressed with a negative weight reading, while forks are on the floor	Lift forks off the ground, press the Zero key	
	Debris between the scale and the forklift carriage	Remove debris	
	Debris between the front and back scale plates	Remove debris	
	Centering pin touching the forklift carriage, causing it to teeter back and forth	Adjust scale carriage, centering pin should not touch on sides and bottom	
	Bottom cleats not adjusted properly or loose	Adjust to proper gap using jam nuts, 0.02"	
	If all these steps do not resolve the issue, check the following		
		Junction box error	Open junction box and look for obvious damage
	Load cell error	Test mV/v levels, at 1.5 mV per 1,000 lb, test at 350 ohms	
Weight inaccurate	Tare key has been activated	At a stable zero weight, press Tare to return scale to normal weighing mode	
Scale not returning to zero (0)	Forks are touching the ground	Lift forks off ground and press the zero key	
	Debris between the scale and the forklift carriage	Remove debris	
	Debris between the front and back scale plates	Remove debris	
	Bottom cleats not adjusted properly or loose	Adjust to proper gap using jam nuts, 0.02"	
	If all these steps do not resolve the issue, check the following		
		Junction box error	Open junction box and look for obvious damage
	Load cell error	Test mV/v levels, at 1.5 mV per 1,000 lb, test at 350 ohms	
Will not display small weight values	Digital filter sensitivity is too high	Using Revolution: Scales menu/scales #1/filtering Change the digital filtering sensitivity to light and change digital filter threshold to 10	
Unstable weight	Power connections faulty, low battery	Check battery power cable Check for low battery voltage	
No weight being displayed on the handheld device	Power switch is off	Turn on power switch	
	Coiled cable has loose connections or wear	Fasten coiled cable connections. Replace coiled cable if damaged	
	If all these steps do not resolve the issue, check the following,		
		Junction box sealing switch is in calibration mode	Move switch to weighing mode
		Junction box load cell connections loose	Securely fasten connections
	Junction box error	Open junction box and look for obvious damage	
	Load cell errors	Test mV/v levels, at 1.5 mV per 1,000 lb, test at 350 ohms	

Table 4-1. CL5 Troubleshooting

5.0 CLS Specifications

Scale Capacity:

5,000 lb x 5 lb NTEP Certified

Scale Power:

Supplied by indicator through coiled interface cable

Scale Material/Finish:

Painted steel

Warranty:

Two-year limited warranty

Certifications and Approvals

CoC Number 06-074 (5,000 lb only) per H-44
at 1,000 divisions

Accuracy Class III/III L

n_{max} : 10 000



RICE LAKE[®]
WEIGHING SYSTEMS

© Rice Lake Weighing Systems Specifications subject to change without notice.
Rice Lake Weighing Systems is an ISO 9001 registered company.

