

# CLS-920i® Wireless Version

## Cargo Lift Scale

### Standard Features

#### Scale Carriage

- Compatible with Class II 16 in (H) or Class III 20 in (H) forklift cleat type carriages
- Out of level NTEP Certified tolerance at seven degrees pitch and roll, three degrees side to side
- 1 1/2 in - thick front and back painted steel plates coupled by 4 flexures
- Top cleats are welded, pinned and bolted
- Welded centering pin
- Two 5,000 lb s-beam load cells
- Updated iQube<sup>2</sup> junction box with inclinometer
- Molded coiled cable, up-to 15ft uncoiled

#### 920i Indicator

- (W x H) 4.6 x 3.4 in, back lit LCD graphical display (320 x 420 pixels)
- Standard user program with data collection and limited transaction storage including selectable tracking number, employee ID, pallet dimensions, product and customer fields. Selectable built in applications such as checkweigh, accumulation, auto store and more. See operators guide for more details.
- Front panel calibration or calibrate through iQube<sup>2</sup> junction box using Revolution<sup>®</sup> software
- 64,000 lb user on-board RAM with storage for 50 product tables and 300 weighments
- On/Off switch to conserve forklift battery life
- Painted mild steel enclosure
- 2 piece top cage indicator mounting assembly with vibration mounts
- 2 available RS-232 ports for added options of scanner, Wi-Fi or printer
- 10-60 VDC power supply for use on propane or electric forklift

#### 802.15 Wireless Load Cell Kit with Rechargeable Smart Lithium Ion Batteries

- 802.15 wireless load cell kit from scale to indicator
- Eliminates coiled cable from junction box to indicator for use with 2 and 3 stage masts
- Reinforced battery box welded onto cover plate to withstand harsh forklift environment
- On/Off switch with LED and antenna mounted on the rear of the enclosure
- Battery life, minimum 24 hours constant use with only 8 hours to fully charge
- Battery life indication, located on the lithium battery
- Includes 2 lithium ion smart batteries and charger
- Not intended for outdoor use

#### Printer and Scanner Recommendations

- Rice Lake recommends using Datamax Microflash 2te and Motorola DS457 Fixed Mount Scanner

#### Presale Requirements

- Provide completed forklift questionnaire for quotation. A pre-installed load backrest on the forklift may interfere with flexures or wireless load cell interface option
- Compatible with most Class II and Class III forklift attachments, consult factory

#### Installation Recommendations

- When installing a forklift scale on an electric forklift, static discharge protection must be present on the forklift and install a chassis mount power conditioner to protect forklift electronics
- When installing a forklift scale, OSHA requires the end user to de-rate the lift capacity of the forklift, see questionnaire for details



### APPROVALS



### Specifications

#### Scale Capacity:

- 28 in and 34 in: 5,000 lb x 5 lb NTEP Certified
- 38 in: 8,000 lb x 5 lb non-type approved

#### Scale Material/Finish:

Stainless steel

#### 920i Dimensions

(W x L x H): 10.5 x 11.2 x 4.5 in (266 x 217 x 114 mm)

#### 920i Power - DC:

- Line voltage: 10 – 60 VDC, DC input
- Power consumption: 1.5 A max fused at 5.0 A

#### 920i Operating Temperature:

- Legal: 14° F to 104° F (-10° C to 40° C)
- Industrial: 14° F to 122° F (-10° C to 50° C)

#### Wireless LAN Option:

- Contains FCC ID: R68WIPORATG
- Range: Up to 328 ft indoors
- Operating Frequency: ISM 2.4 GHz

#### Warranty:

Two-year limited warranty

#### Approvals:

NTEP CC 06-074 (5,000 lb only) per H-44 at 1,000 divisions



www.nascoop.com | Phone: 800-321-3396

# CLS-920i<sup>®</sup> WirelessVersion

## Cargo Lift Scale

Front view

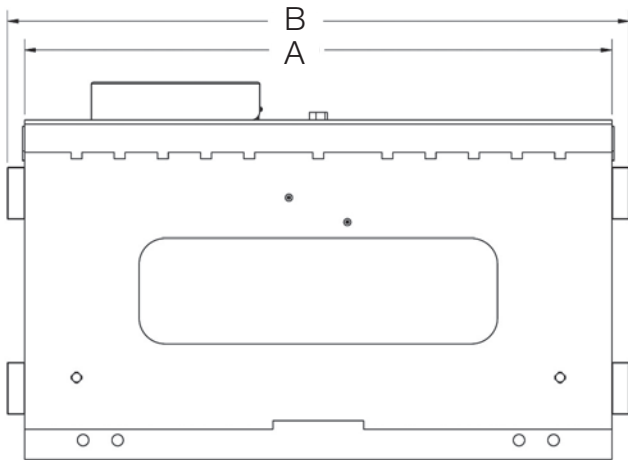

CLS DIMENSIONS			
<b>28 in, 5000 lb</b>			
A	28	E	19.50
B	30	F	4.49
C	16	G	21.80
D	16.29	H	28.24
<b>34 in, 5000 lb</b>			
A	34	E	19.50
B	36	F	4.49
C	16	G	21.80
D	16.29	H	34.24
<b>38 in, 8000 lb</b>			
A	38	E	24.50
B	40	F	6.04
C	20	G	26.68
D	20.15	H	38

Side view

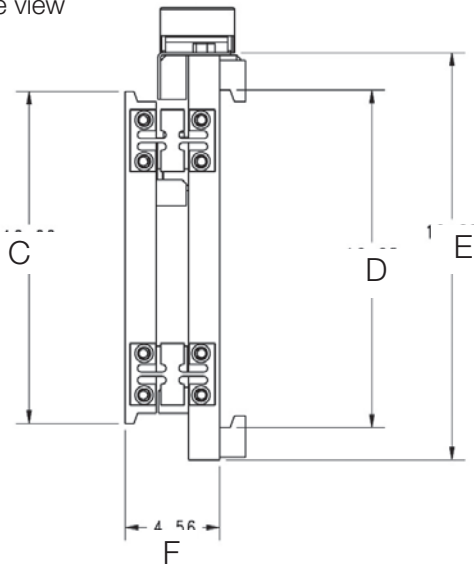

Rear view

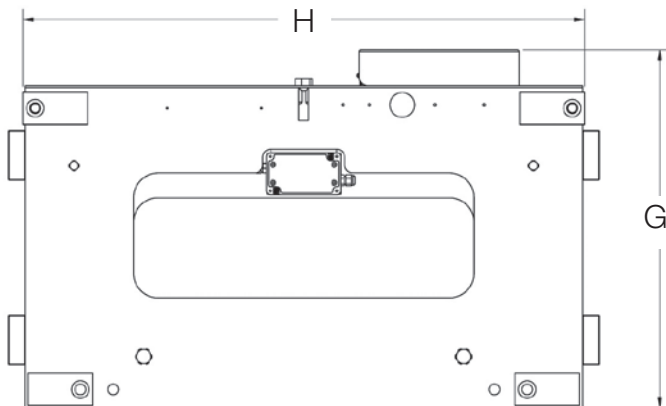

# CLS-920i® WirelessVersion

Cargo Lift Scale

## Part Number/Price

PART #	SIZE, CAPACITY	FORKLIFT COMPATIBILITY	WEIGHT	PRICE
<b>CLS Forklift Scale, 920i Wireless Version</b>				
167421	5,000 lb x 5 lb NTEP Certified	28 in W, Class II 16 in (H) forklift carriage (30 in W with flexures) 10-60 VDC	524 lb	Consult
171809	5,000 lb x 5 lb NTEP Certified	34 in W, Class II 16 in (H) forklift carriage (36 in W with flexures) 10-60 VDC	539 lb	Consult
167413*	8,000 lb x 5 lb non-Legal for Trade	38 in W, Class III 20 in (H) forklift carriage (40 in W with flexures) 10-60 VDC	1144lb	Consult

\*Non-NTEP Certified

If used with electric forklift, manufacturer recommends adding part number 166161 to protect electronics against static

## Options/Accessories

The following options and replacements parts below are available to use for the part numbers referenced above. To order replacement parts and options for products purchased prior to this catalog, contact the factory for assistance.

PART #	DESCRIPTION	PRICE
96355	Wireless LAN card 802.11 B/G, requires factory installation	Consult
167498	6.5 ft straight extension cable to coiled cable	Consult
166161	DC Emi filter, chasis mount, 0-75 VDC input, 100 VDC surge protection	Consult
166162	DC-DC converter, chasis mount, 18-75 VDC input, 12 VDC output	Consult
<b>Replacement Parts</b>		
96915	Power cable assembly with power fuse cable	Consult
130129	Power fuse cable assembly	Consult
166623	RL20000 FLS load cell 5,000 lb 1.5 mV/V 350 ohm with turk connectors	Consult
166756	RL20000 FLS turk load cell connector	Consult
167999	CLS-M / 920i iQube <sup>2</sup> ® PCB assembly	Consult
96344	Battery charger	Consult
96343	Battery, forklift lithium ion	Consult



www.nascoop.com | Phone: 800-321-3396