

RailBoss™

Railroad Track Scale

Installation Manual



RICE LAKE[®]
WEIGHING SYSTEMS

PN 119903 Rev G

Contents

- 1.0 Introduction..... 1**
 - 1.1 Prior to Installation 1
 - 1.1.1 Rail Size 1
 - 1.1.2 Condition of Existing Track 1
 - 1.2 Safety..... 2
- 2.0 RailBoss Installation..... 3**
 - 2.1 Preparing and Cutting Existing Rail 3
 - 2.2 Tie Spacing and RailBoss Mounting 4
- 3.0 Junction Box Installation..... 6**
 - 3.1 Junction Box Wiring 6
 - 3.2 Cable Grounding 7
 - 3.3 920i Wiring 8
- 4.0 Grounding..... 9**
 - 4.1 Ground Rod Locations 9
 - 4.2 Grounding System Installation 10
- 5.0 Calibration 11**
 - 5.1 Using the RailBoss Calibrator..... 11
 - 5.2 Trimming the Junction Box..... 12
 - 5.3 Calibrating the 920i 13
 - 5.3.1 Front Panel Calibration 14
 - 5.3.2 iRev Calibration..... 15



Technical training seminars are available through Rice Lake Weighing Systems. Course descriptions and dates can be viewed at www.ricelake.com/training or obtained by calling 715-234-9171 and asking for the training department.



Rice Lake continually offers web-based video training on a growing selection of product-related topics at no cost. Visit www.ricelake.com/webinars.

1.0 Introduction

This manual is intended for use by technicians responsible for installing and servicing the *RailBoss Railroad Track Scale*.



Important Use the instructions in this manual as general installation guidelines, unless they differ from the engineering drawings that are furnished with the scale. Engineering drawings always take priority over the manual



Manuals can viewed or downloaded from the Rice Lake Weighing Systems website at www.ricelake.com.

Unpack the contents of the shipment and verify the contents are correct. Check for damage that could have occurred during shipment, and report any discrepancies immediately.

The *RailBoss Railroad Track Scale* is available in Double-Draft and Full-Draft versions.

Double draft mode will weigh one set of rail trucks (all four wheels) at a time. This is optimal for rail cars that do not fit on the *RailBoss Railroad Track Scale* or for installations consisting of only one four-rail section.

Full-draft weighments require a dual-channel A/D input card installed in the *920i*, and two four-rail sections of the *RailBoss Railroad Track Scale*.

Before installing, ensure you have the following:

- *RailBoss* joint bars, nuts, and bolts
- Compromise bars (only if in-bound and out-bound rails do not match *RailBoss* rails)
- Conduit and cable
- JB4SP Junction box (one for double-draft, two for full draft)
- If necessary, new railroad ties
- All mounting hardware and related items

Recommended tools:

- Rail saw
- Rail drill
- Rail lifters
- Anchor and spike extractor
- Striking hammer
- Pneumatic hammer and wrench

Assorted mechanical and electrical tools

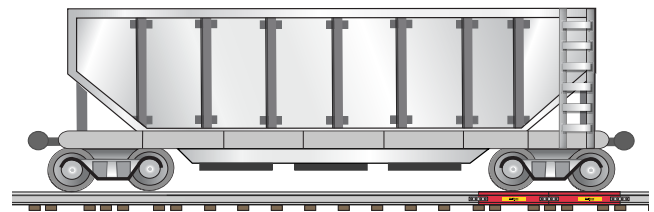


Figure 1-1. Double-Draft Installation

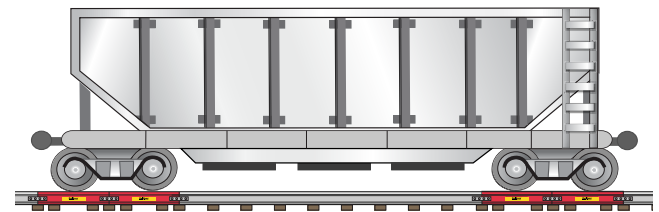


Figure 1-2. Full-Draft Installation



Note Actual installation of rail sections, including rail cutting, tie positioning, and rail installation is recommended to be performed by a licensed rail contractor.

1.1 Prior to Installation

Prior to the installation date, inspect the site, paying close attention to rail size and existing track condition.

1.1.1 Rail Size

Before installing the *RailBoss Railroad Track Scale*, ensure the *RailBoss* rail size matches the existing rail size. If the rail size does not match, compromise bars will be needed.

1.1.2 Condition of Existing Track

Existing rail and railroad ties should be in good condition. Rail must adhere to main line standards (maximum deflection 1/4" under load).

Existing ties and ballast should show no signs of damage or rot. Replacement of existing ties is recommended to ensure the *RailBoss Railroad Track Scale* properly functions.

1.2 Safety

Safety Symbol Definitions:



Indicates an imminently hazardous situation that, if not avoided, will result in death or serious injury.



Indicates a potentially hazardous situation that, if not avoided could result in serious injury or death, and includes hazards that are exposed when guards are removed.



Indicates a potentially hazardous situation that, if not avoided may result in minor or moderate injury.



Indicates information about procedures that, if not observed, could result in damage to equipment or corruption to and loss of data.

General Safety



Do not operate or work on this equipment unless you have read and understand the instructions and warnings in this manual. Failure to follow the instructions or heed the warnings could result in injury or death. Contact any Rice Lake Weighing System dealer for replacement manuals. Proper care is your responsibility.



Failure to heed may result in serious injury or death.

DO NOT allow minors (children) or inexperienced persons to operate this unit.

DO NOT operate without all shields and guards in place.

DO NOT use for purposes other than weight taking.

DO NOT place fingers into slots or possible pinch points.

DO NOT use any load bearing component that is worn beyond 5% of the original dimension.

DO NOT use this product if any of the components are cracked.

DO NOT exceed the rated load limit of the unit.

DO NOT make alterations or modifications to the unit.

DO NOT remove or obscure warning labels.

Keep hands, feet and loose clothing away from moving parts.

2.0 RailBoss Installation

Installation time will vary; however, a typical installation will take approximately 10-15 hours. Use the instructions below as a general installation guideline unless the engineering drawings furnished with your scale differ. Engineering instructions always take priority over these general installation guidelines.



The RailBoss Scale is heavy and could cause bodily harm if any body parts become entangled with or caught under it when installing. Take all necessary safety precautions when installing, including wearing safety shoes and using the proper tools.

2.1 Preparing and Cutting Existing Rail

1. Clear the existing ballast surrounding the track where RailBoss section(s) are to be installed.
2. Measure section(s) of track to be replaced with the RailBoss Railroad Track Scale. Mark the four cutting locations (eight cuts for a full-draft installation).
3. Clear out the area underneath the rail where cutting will occur.



Figure 2-1. Existing Track Cleared of Ballast

4. Remove existing railroad spikes and tie plates.
5. Secure a rail saw to existing track at the cutting marks established in Step 2. Once mounted, completely cut through the rail.



Figure 2-2. Cutting Existing Track

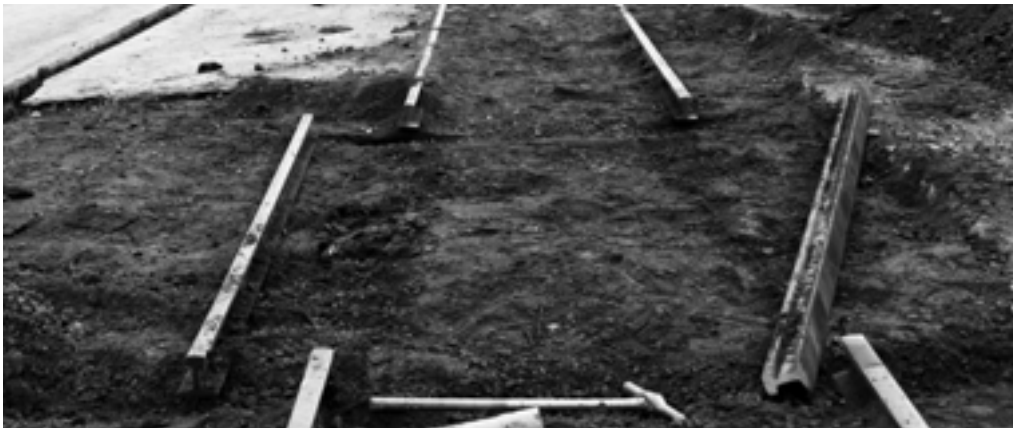


Figure 2-3. Rail Cutting Complete

6. Once all cuts have been made, remove the loose rails from the area.

2.2 Tie Spacing and RailBoss Mounting

1. Use a back hoe to dig through existing ballast and remove the existing ties.



Installing new ties is recommended; if existing ties are in good condition, they will still need to be removed to allow for alignment and spacing needs beneath the RailBoss sections.

2. Drill two standard-spaced 1.25" holes in existing rail to allow for RailBoss mounting.



Figure 2-4. Holes Drilled in Existing Rail

3. Place ties in position, 36" apart, according to the yellow or red marks at the base of the rail. See Figure 2-5.

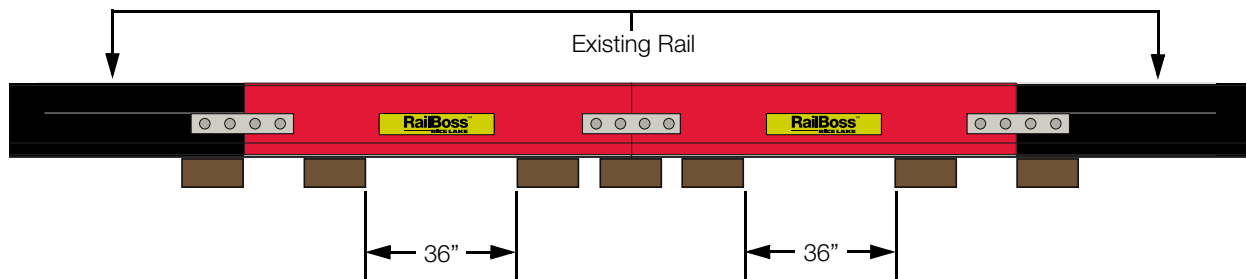


Figure 2-5. Tie Spacing in Relation to Existing Rail and Installed RailBoss



Rails may be turned 180 degrees to keep the cables on the inside of the rails.

4. Adjust ballast beneath ties as necessary to maintain plumb.
5. Install RailBoss sections by inserting bolts through pre-drilled holes in the RailBoss and joint bars (or compromise bars if needed). Finger-tighten one nut on each bolt. Four hole joint bars must be used to join in-bound and out-bound rails with RailBoss rails. The use of six hole joint bars is not permitted.



Figure 2-6. RailBoss Sections in Place

6. Use a pneumatic wrench to tighten nuts on all joint or compromise bars.
7. Ensure tie spacing is correct, then drive spikes to attach tie plates to the rail ties; drive spikes fully into place with a pneumatic hammer if available.

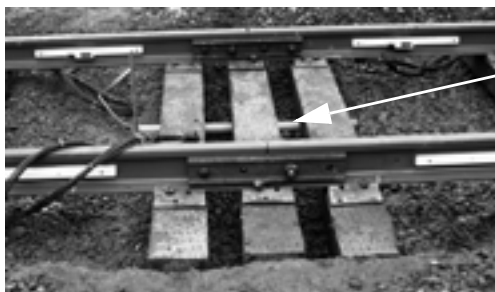


Note If using rail hammers, ensure the RailBoss is not inadvertently struck.

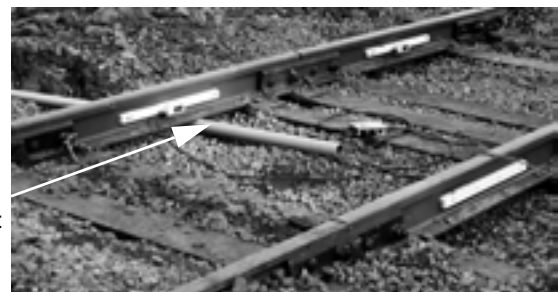


Figure 2-7. Drive Spikes Through Tie Plates

8. Place watertight conduit beneath the three center rail ties and route load cell cables to the desired j-box location. Watertight conduit should also be placed beneath the RailBoss track to run homerun cable to the scale house indicator (see Figure 2-8 and Figure 2-8).



Load cell
cable conduit



Homerun
cable conduit

Figure 2-8. Load Cell Cable and Homerun Cable Conduit

9. Replace ballast and spread evenly; do not compact ballast until installation of ground rods is complete.
10. Ensure there is 1/8" minimum clearance between the RailBoss rail sections.

3.0 Junction Box Installation

The RailBoss Railroad Track Scale TuffSeal® junction box (PN 119987) has been designed to connect and trim four load cells per board. One junction box is required per RailBoss section (i.e., one for double-draft systems, two for full-draft systems).



WARNING *Electrostatic Charging Hazard*

To prevent Electrostatic charging hazard, the equipment shall only be cleaned with a damp cloth. Sparks can ignite flammable liquid vapors and powders.

3.1 Junction Box Wiring

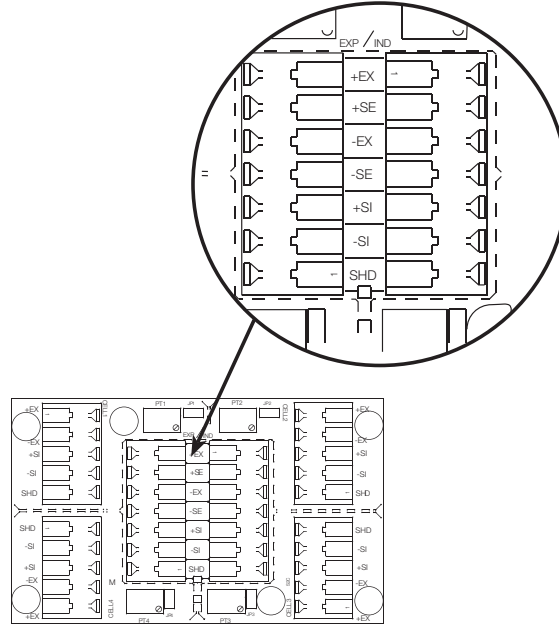


Figure 3-1. Expansion Port Wiring Location

Wiring assignments are listed in Table 3-1.



Note *Version 2 = yellow cover*

Version 1 = white cover

V2 – Yellow Cover	
Color	Function
Green	+EXCITATION
Black	-EXCITATION
White	+SIGNAL
Red	-SIGNAL

V1 – White Cover	
Color	Function
Red	+EXCITATION
Black	-EXCITATION
Green	+SIGNAL
White	-SIGNAL

Table 3-1. RailBoss Wiring Assignments

1. Route the load cell cables through the cord grip assemblies and leave the grips loose until final closure. See Figure 3-1 and Table 3-1.
2. Before connecting load cell wires to the terminals, strip the wire insulation back 1/4" to expose the wire. The spring-loaded terminals will accommodate 12-28 gauge wire.
3. To connect the load cell wires to the appropriate connectors, push in the quick-connect lever with a small screwdriver. While holding the lever, insert the appropriate wire into the exposed wire opening. Release the screwdriver to allow the spring-loaded gate to close and lock the wire in place.

Serial Port Assignments

A single or dual A/D card can be used with the scale depending on if it is a full draft or double draft.

- Dual A/D card – Full Draft
- Single A/D card – Double Draft

Table 3-2 shows the port numbers assigned for each slot.

Slot Number	Serial Port Assignment
1	1 - Printer (for railcar ticket - defaults to 9600, None, 8 bits, parity 1)
	2 - iRev
	3 - not used
	4- not used

Table 3-2. Serial Port Assignments

3.2 Cable Grounding

Except for the power cord, all cables routed through the cord grips should be grounded against the indicator enclosure.

1. Use the lock washers, clamps, and keps nuts provided in the parts kit to install grounding clamps on the enclosure studs adjacent to cord grips. Install grounding clamps only for cord grips that will be used; do not tighten nuts.
2. Route cables through cord grips and grounding clamps to determine cable lengths required to reach cable connectors.
3. Strip the insulation and foil from the cable half an inch (15 mm) past the grounding clamp (see Figure 3-2). Fold the foil shield back on the cable where the cable passes through the clamp. Ensure silver (conductive) side of foil is turned outward for contact with the grounding clamp.

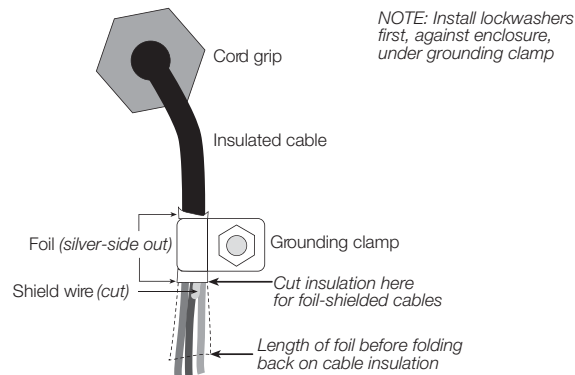


Figure 3-2. Grounding Clamp Attachment

4. Cut the shield wire just past the grounding clamp. Shield wire function is provided by contact between the cable shield and the grounding clamp.
5. Route stripped cables through cord grips and clamps. Ensure shields contact grounding clamps as shown in Figure 3-2. Tighten grounding clamp nuts.
6. Finish installation using cable ties to secure cables inside of indicator enclosure.

3.3 920i Wiring

1. Route the cable through the cord grip and ground the shield wire as described in Section 3.2.
2. Remove connector J1 from the A/D card. The connector plugs into a header on the A/D card (see Figure 3-3). Wire the load cell cable from the load cell or junction box to connector J1 as shown in Table 3-3.

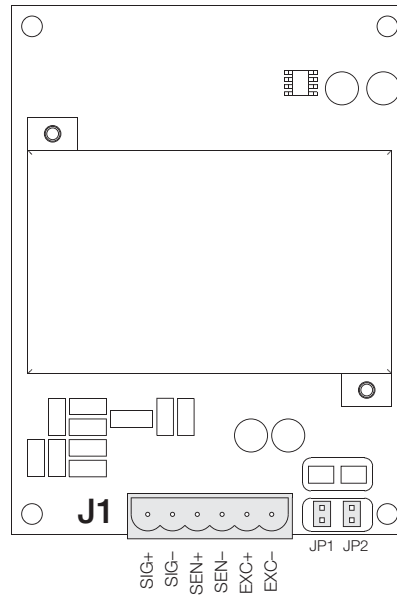


Figure 3-3. Single-Channel A/D Card

A/D Card Connector Pin	Function
1	+SIG
2	-SIG
3	+SENSE
4	-SENSE
5	+EXC
6	-EXC
<ul style="list-style-type: none"> • For 6-wire load cell connections to connector J1, remove jumpers JP1 and JP2. • For 6-wire load cell connections to connector J2 (dual A/D cards), remove jumpers JP3 and JP4. 	

Table 3-3. A/D Card Pin Assignments

3. If using 6-wire load cell cable (with sense wires), remove jumpers JP1 and JP2 before reinstalling connector J1. For 4-wire installation, leave jumpers JP1 and JP2 on. For 6-wire load cell connections on dual-channel A/D cards, remove jumpers JP3 and JP4 for connections to J2.
4. When connections are complete, reinstall load cell connector on the A/D card and use two cable ties to secure the load cell cable to the inside of the enclosure.



Note Because cables could be exposed to water or other liquids, bend a short downward loop in all cables near the cord grips so any fluids draining down the cables will drip off before reaching the junction box.

4.0 Grounding

Rice Lake Weighing Systems strongly recommends installation of the *RailBoss* grounding system to protect the *RailBoss Railroad Track Scale* from surges. Rail track scales of all types can be exposed to surges or lightning that may hit the rail at even very long distances from the scale. It is recommended that scale sections be isolated from the rail track on both ends of each section. Eight-foot ground rods should be driven between the rails, and a copper wire connected to the rail on each side with a 10-gauge copper wire. Rail joint bar isolators should also be installed at each end of *RailBoss* sections.

Replacement Part Numbers

Part Number	Description
126111	Rail Joint Bar Isolator kit, 90 RE Full or Double Draft
112702	Rail Joint Bar Isolator kit, 115 RE Full or Double Draft
119771	Rail Joint Bar Isolator kit, 132 RE Full or Double Draft

Table 4-1. Rail Joint Bar Isolator Kits

Part Number	Description	Grounding Kit Contents (Qty)
119800	Grounding kit, 115 lb RE Double Draft	110812, UPS Sola S1K520, (1)
119801	Grounding kit, 115 lb RE Full Draft	119913, 8' Copper bonded steel ground rod (2)
119802	Grounding kit, 132 lb RE Double Draft	119916, Ground rod clamp (2)
119803	Grounding kit, 132 lb RE Full Draft	119917, Pipe clamp, grounding (4)
		119920, Copper wire, 10 ga. 25' (1)

Table 4-2. Grounding Kit Part Numbers

4.1 Ground Rod Locations

Ground rod placement can vary depending on ground hardness; however, 8' ground rods should be installed near the center of the track. See Figure 4-1 and 4-2 for recommended ground rod locations.

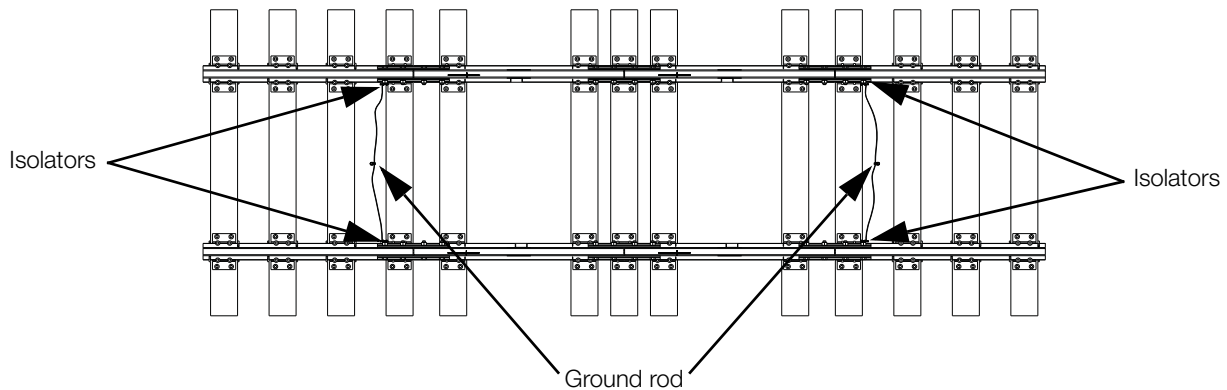


Figure 4-1. Ground Rod Locations in Double-Draft System

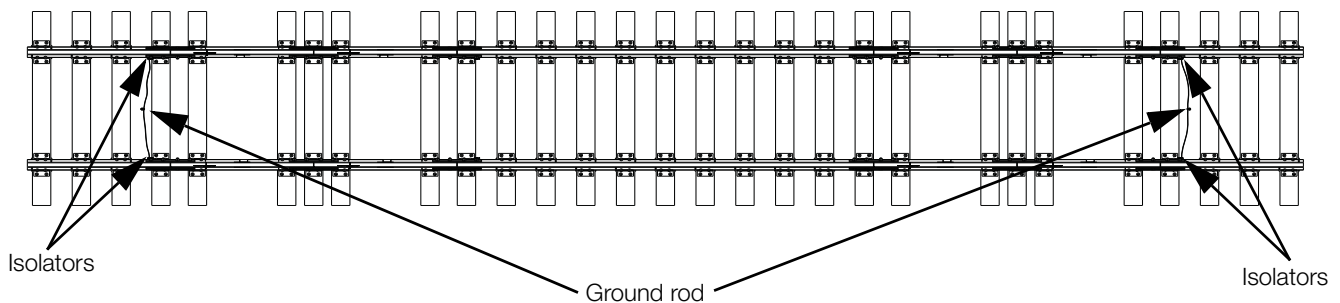


Figure 4-2. Ground Rod Locations in Full-Draft System

4.2 Grounding System Installation

1. Install ground rods (purchased separately from the RailBoss grounding system) at the locations specified in Section 4.1. Rods should be driven into the ground so the tip is at the approximate height of railroad tie surfaces.
2. Once rods are installed, ballast can be compacted.
3. Ensure there is a solid ballast foundation under the ties.
4. Install ground rod clamps on ground rods (see Figure 4-3).

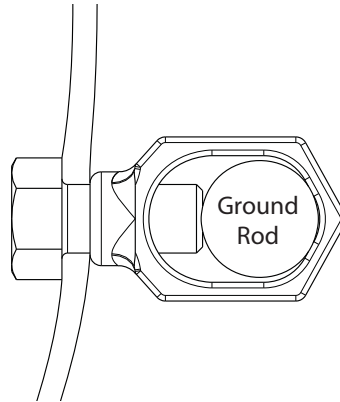


Figure 4-3. Ground Clamp Installed on Ground Rod

5. Install pipe grounding clamps on joint bar bolts (see Figure 4-4).

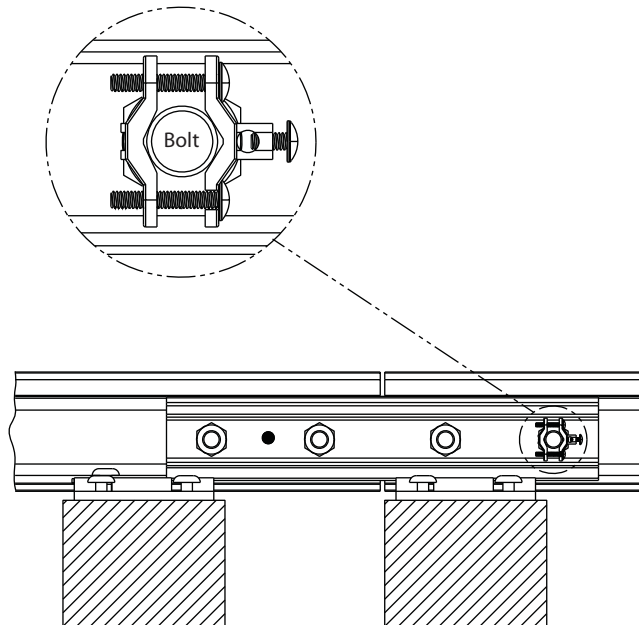


Figure 4-4. Ground Clamp Installed on Joint Bar Bolts

6. Route 10-gauge copper wire from the pipe grounding clamps to the ground rod clamps and cut to length.
7. Install the UPS (uninterruptedly power system).

5.0 Calibration

The *RailBoss Calibrator* is a specially designed tool to effectively calibrate the RailBoss Railroad Track Scale.

5.1 Using the RailBoss Calibrator

1. Prior to placing the *RailBoss Calibrator* on the track, ensure track grips are arranged as shown in Figure 5-1.

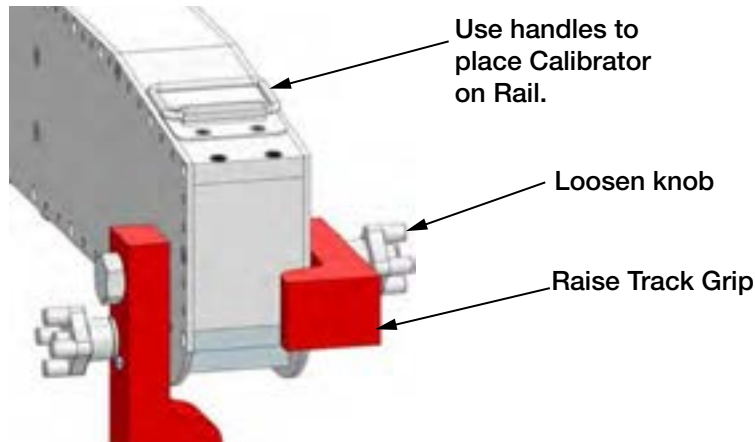


Figure 5-1. RailBoss Calibrator Track Grips

2. Place the *RailBoss Calibrator* on the *RailBoss* rail, centering the calibrator load cell over the center of the yellow reflective strip.

! **Important** This ensures a correct reading from the rail.

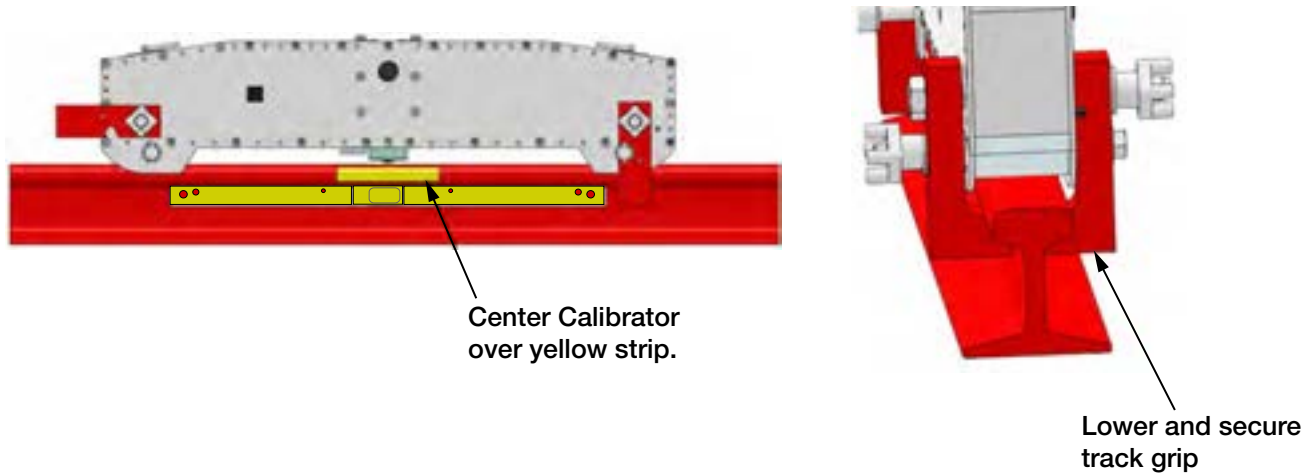


Figure 5-2. RailBoss Calibrator on RailBoss Scale

3. With the calibrator securely fitted over the *RailBoss* live rail, attach the indicator and hydraulic pump.

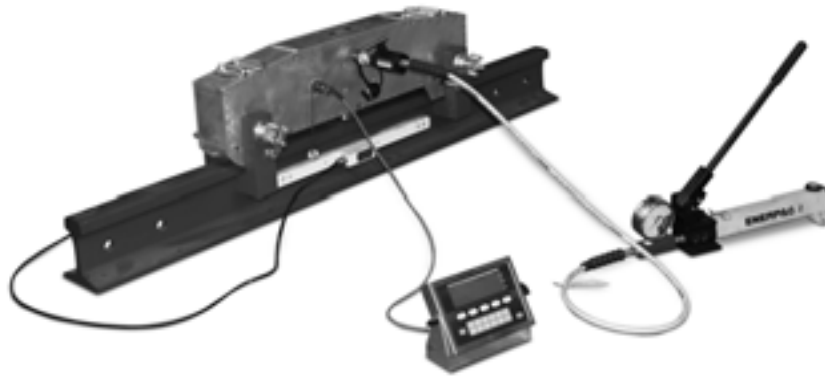


Figure 5-3. Indicator and Hydraulic Pump Attached to RailBoss Calibrator

4. Engage the pump by closing the release valve located on the side of the pump (turn clockwise).
5. Pump until weight reaches 30,000 lb and release pressure until weight returns to zero.
6. Repeat steps 4 & 5 two more times before attempting to calibrate.



Note Hydraulic cylinders tend to bleed down at a slow rate.

If weight does not stabilize, repeat step 4-6.

7. Calibrate the indicator to match the scale's 30,000 lb. load (see Section 5.1). If weight is not stable, repeat Step 4.
8. Repeat Steps 1 - 7 on each RailBoss rail.
9. Once calibration is complete on all RailBoss rails, disconnect the hydraulic pump and indicator.

5.2 Trimming the Junction Box

Trimming is a process of equalizing the output from multiple individual load cells. If needed, load cell output can be individually trimmed with potentiometers. Whenever a substantial amount of trim (more than 5% of normal output), seems necessary to equalize output, check for other possible problems. The best trim is always the least amount of trim. When all errors except cell mismatch and cable extensions or reductions have been corrected, continue with the trimming

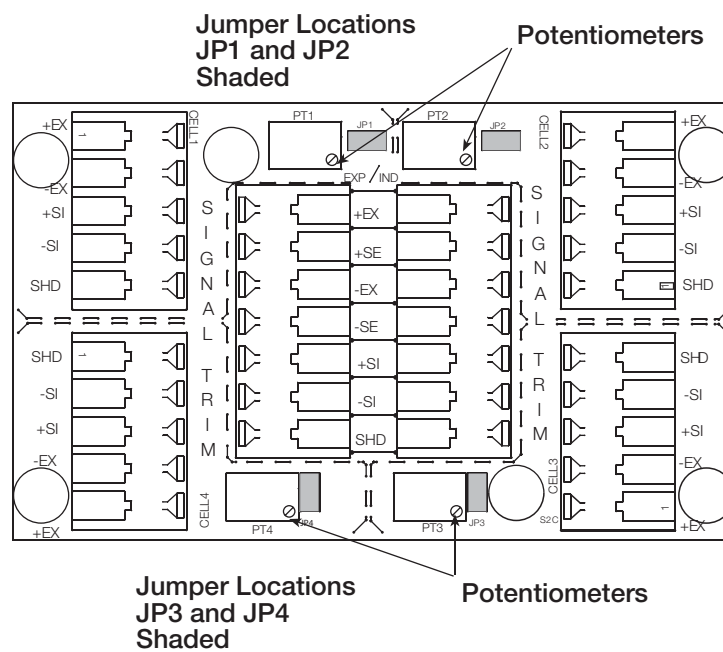


Figure 5-4. Signal Trim Main Board

Use the following steps to properly trim the JB4SP junction box.

1. Make sure jumpers are in place to enable trimming of the cells corresponding to each load cell. See Figure 5-2 for the location of jumpers JP1, JP2, JP3, and JP4.
2. Set all potentiometers fully clockwise to give maximum signal output from each cell (see Figure 5-2 for location of potentiometers)
3. Zero the indicator and place the *RailBoss* Calibrator over each load cell in turn. The amount of test weight is recommended to be 30,000 lb.
4. Record the value displayed on the indicator after the calibrator is placed in turn on each load cell. Allow the scale to return to zero each time to check for friction or other mechanical problems. Select the load cell which has the lowest value as your reference point. This cell will not be trimmed.
5. Replace the same test load over each cell in turn. Using the corresponding potentiometer, trim each cell down to equal the reference load cell. check all cells again for repeatability and, if necessary, repeat Steps 3 and 4.
6. Pull excess cable out of the enclosure and tighten the cord grip assemblies with a wrench. To be watertight, each cord grip must be tightened so the rubber sleeve begins to protrude from the hub.
7. Unused hubs must be properly plugged to prevent moisture entry. See Rice Lake's Electronic Replacement Parts Catalog to order extra hole plugs.
8. Remove the desiccant from the plastic bag, and insert the desiccant bag into the junction box before closing. Inspect the desiccant during normal service and change as needed.
9. Replace the cover and torque the cover screws in an alternating pattern. Torque to 15 in/lb to be certain the gasket is compressed equally in all locations.

5.3 Calibrating the 920i

The 920i can be calibrated using the front panel, serial commands, or iRev 4. Each method consists of the following steps:

- Zero calibration
- Entering the test weight value
- Span calibration

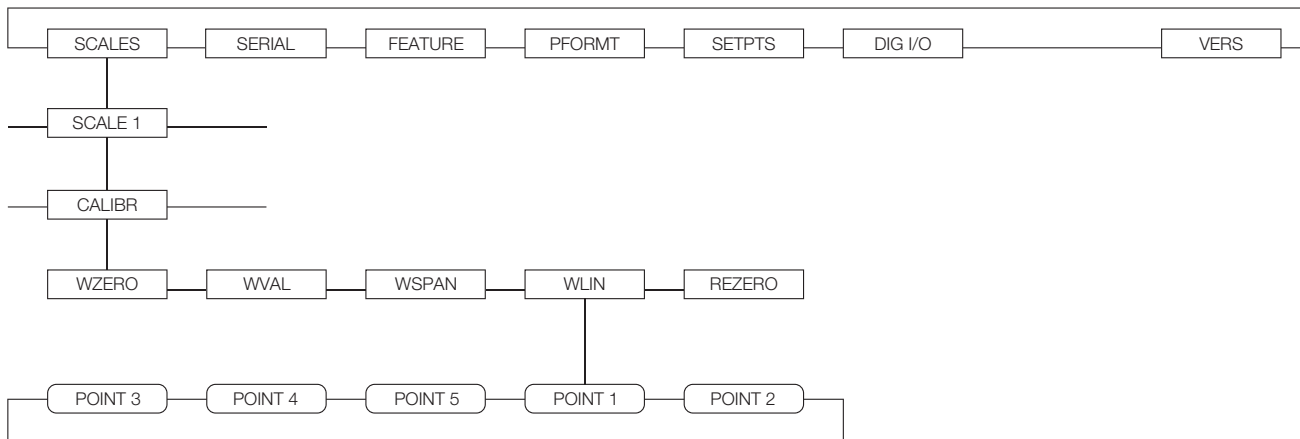


Figure 5-5. Calibration (CALIBR) Submenu

5.3.1 Front Panel Calibration

The CALIBR submenu (under the SCALES menu, see Figure 5-6) is used to calibrate the 920i. The zero, span, and linear calibration point displays provide a set of softkeys used specifically for calibration procedures:

- +/-** Toggles to allow entry of negative or positive values
- Last Zero** Recalls the last established zero value to allow calibration without removing tests weights or product from scale.
- Calibrate** Performs calibration for the selected point
- Temp Zero** Temporarily zeroes the displayed weight of a non-empty scale. After span calibration, the difference between the temp zero and the previously calibrated zero value is used as an offset.
- Millivolts (or Counts)** Toggles between display of captured A/D counts and captured millivolts values; allows entry of calibration values in mV or counts

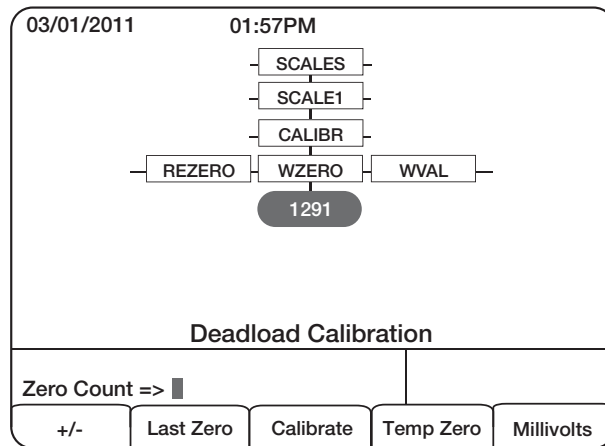


Figure 5-6. WZERO Calibration Display

To calibrate the indicator using the front panel, do the following:

1. Ensure the J-Box trimming procedure has been successfully completed.
2. Place the indicator in setup mode by removing the large fillister-head screw from the enclosure. Insert a screwdriver or similar tool into the access hole and press the setup switch once. The indicator display changes to show scale configuration menus.
3. With the **SCALES** menu highlighted, press the down key, then select the Scale 1. Press down again (**GRADS** parameter highlighted), then press left to highlight the **CALIBR** sub-menu (see Figure 5-5). Press down to go to zero calibration (**WZERO**). See Figure 5-6.
4. Ensure scale reading is at zero, then press down again to show the current **WZERO** value, then press the **Calibrate** softkey to calibrate zero. When complete, the new A/D count for the zero calibration is displayed. Press Enter to save the zero calibration value and go to the next prompt (**WVAL**).
5. With **WVAL** displayed, press down to show the stored calibration weight value. Use the numeric keypad to enter the actual value of the *RailBoss Calibrator* load to be used (30,000 lbs. is recommended), then press Enter to save the value and go to span calibration (**WSPAN**).
6. Use the *RailBoss Calibrator* to place a 30,000 lb. load on the scale. Press down again to show the current **WSPAN** value, then press the **Calibrate** softkey to calibrate span. When complete, the new A/D count for the span calibration is displayed. Press Enter again to save the span calibration value and go to the next prompt (**WLIN**).
7. When complete, press the **Save and Exit** softkey to exit setup mode.

5.3.2 iRev Calibration

The iRev 4 Calibration Wizard provides step-by-step scale calibration. With the 920i connected to a PC, select the Calibration Wizard from the Tools menu on the iRev 4 Scales display, then follow the steps listed below to calibrate the scale.

1. On the first Calibration Wizard display (see Figure 5-7), select Standard Calibration. Click the **Next** button to continue.



Figure 5-7. iRev 4 Calibration Wizard

2. Select the scale to calibrate (Scale #1).



Figure 5-8. iRev 4 Scale Selection Display

3. Enter the RailBoss Calibrator load value used to calibrate the scale (30,000 lb).



Figure 5-9. iRev 4 Test Weight Value Display

4. Ensure the scale load is at zero. Press the **Calibrate Zero** button to perform the zero calibration. A message appears when the process is complete.



Figure 5-10. iRev 4 Zero Calibration Display

5. Using the RailBoss Calibrator, apply the 30000 load to the scale (see Section 5.1). Press the **Calibrate Span** button to perform the span calibration. A message appears when the process is complete.



Figure 5-11. iRev 4 Span Calibration Display

6. Review the new calibration values then click **Finish** to close the Calibration Wizard. To restore the current calibration values, click **Cancel**.

RailBoss Limited Warranty

Rice Lake Weighing Systems (RLWS) warrants that all RLWS equipment and systems properly installed by a Distributor or Original Equipment Manufacturer (OEM) will operate per written specifications as confirmed by the Distributor/OEM and accepted by RLWS. All systems and components are warranted against defects in materials and workmanship for two years.

RLWS warrants that the equipment sold hereunder will conform to the current written specifications authorized by RLWS. RLWS warrants the equipment against faulty workmanship and defective materials. If any equipment fails to conform to these warranties, RLWS will, at its option, repair or replace such goods returned within the warranty period subject to the following conditions:

- Upon discovery by Buyer of such nonconformity, RLWS will be given prompt written notice with a detailed explanation of the alleged deficiencies.
- Individual electronic components returned to RLWS for warranty purposes must be packaged to prevent electrostatic discharge (ESD) damage in shipment. Packaging requirements are listed in a publication, *Protecting Your Components From Static Damage in Shipment*, available from RLWS Equipment Return Department.
- Examination of such equipment by RLWS confirms that the nonconformity actually exists, and was not caused by accident, misuse, neglect, alteration, improper installation, improper repair or improper testing; RLWS shall be the sole judge of all alleged non-conformities.
- Such equipment has not been modified, altered, or changed by any person other than RLWS or its duly authorized repair agents.
- RLWS will have a reasonable time to repair or replace the defective equipment. Buyer is responsible for shipping charges both ways.
- In no event will RLWS be responsible for travel time or on-location repairs, including assembly or disassembly of equipment, nor will RLWS be liable for the cost of any repairs made by others.

THESE WARRANTIES EXCLUDE ALL OTHER WARRANTIES, EXPRESSED OR IMPLIED, INCLUDING WITHOUT LIMITATION WARRANTIES OF MERCHANTABILITY OR FITNESS FOR A PARTICULAR PURPOSE. NEITHER RLWS NOR DISTRIBUTOR WILL, IN ANY EVENT, BE LIABLE FOR INCIDENTAL OR CONSEQUENTIAL DAMAGES.

RLWS AND BUYER AGREE THAT RLWS'S SOLE AND EXCLUSIVE LIABILITY HEREUNDER IS LIMITED TO REPAIR OR REPLACEMENT OF SUCH GOODS. IN ACCEPTING THIS WARRANTY, THE BUYER WAIVES ANY AND ALL OTHER CLAIMS TO WARRANTY.

SHOULD THE SELLER BE OTHER THAN RLWS, THE BUYER AGREES TO LOOK ONLY TO THE SELLER FOR WARRANTY CLAIMS.

NO TERMS, CONDITIONS, UNDERSTANDING, OR AGREEMENTS PURPORTING TO MODIFY THE TERMS OF THIS WARRANTY SHALL HAVE ANY LEGAL EFFECT UNLESS MADE IN WRITING AND SIGNED BY A CORPORATE OFFICER OF RLWS AND THE BUYER.

© Rice Lake Weighing Systems, Inc. Rice Lake, WI USA. All Rights Reserved.

RICE LAKE WEIGHING SYSTEMS • 230 WEST COLEMAN STREET • RICE LAKE, WISCONSIN 54868 • USA

For More Information

Web Site

Frequently Asked Questions (FAQs) at
<http://www.ricelake.com/faqs.aspx>

Contact Information

Hours of Operation

Knowledgeable customer service representatives are available 6:30 a.m. - 6:30 p.m. Monday through Friday and 8 a.m. to 12 noon on Saturday. (CST)

Telephone

Sales/Technical Support 800-472-6703

Canadian and Mexican Customers 800-321-6703

International 715-234-9171

Immediate/Emergency Service

For immediate assistance call toll-free 1-800-472-6703 (Canadian and Mexican customers please call 1-800-321-6703). If you are calling after standard business hours and have an urgent scale outage or emergency, press 1 to reach on-call personnel.

Fax

Fax Number 715-234-6967

Email

US sales and product information at

prodinfo@ricelake.com

International (non-US) sales and product information at

intlsales@ricelake.com

Mailing Address

Rice Lake Weighing Systems

230 West Coleman Street

Rice Lake, WI 54868 USA



© Rice Lake Weighing Systems Specifications subject to change without notice.
Rice Lake Weighing Systems is an ISO 9001 registered company.

230 W. Coleman St. • Rice Lake, WI 54868 • USA

U.S. 800-472-6703 • Canada/Mexico 800-321-6703 • International 715-234-9171 • Europe +31 (0)26 472 1319

www.ricelake.com www.ricelake.mx www.ricelake.eu www.ricelake.co.in m.ricelake.com