

# VICTOR®

PARTS AND SERVICE BULLETIN

## HC 1500C HAND CUTTING TORCH

FORM NO. 56-666

EFFECTIVE 1-89



This torch uses an internal check valve for the pre-heat O<sub>2</sub> and fuel inlet connection. Special attention should be given to the following notes:

### CAUTION

Check valves are mechanical devices that can leak when dirty or if abused. Check valves should be checked at least every six months. Careless usage, dirt or abuse can shorten the service life of check valves, thus requiring more frequent checking. Be sure to test check valves in a well ventilated area! The escaping gases create conditions for fires and explosions!

### NO SMOKING OR OPEN FLAME SHOULD BE ALLOWED IN TEST AREA!

#### TO TEST INTERNAL TORCH CHECK VALVES, FOLLOW THESE STEPS:

1. Adjust both regulator pressure adjusting screws so that no pressure will be delivered.
2. Connect both pre-heat hoses to the torch.
3. Disconnect one hose from one regulator.
4. Open all torch pre-heat control valves.
5. Plug end of tip.
6. Adjust the regulator that is **NOT DISCONNECTED** until a 2-5 PSIG reading is obtained on the low pressure gauge.
7. Put the end of the hose that is disconnected from the regulator under water for 10 seconds or cover end of hose with approved leak detector solution.
8. Bubbles will develop if the check valve is leaking. There should be no more than one bubble in 10 seconds.
9. If the check valve is leaking, reconnect the hose to the regulator and unplug the tip. Flush for 3-5 seconds with 10 PSIG fuel gas or 30 PSIG oxygen, depending on the check valve being tested.
10. Retest check valve. If the check valve is still leaking, it must be replaced with a new one.
11. To test the other check valve, reconnect the hose that was disconnected for the first test and disconnect the other hose.
12. Follow the same procedure as for first test.
13. After both check valves have been tested and are good, purge both the oxygen and fuel lines before lighting torch.

Victor recommends that if an internal check valve is removed for any reason it should be thoroughly cleaned and tested after re-installation.

## WARNING

**Welding apparatus improperly maintained or repaired can be dangerous. Some parts and accessories manufactured by others may fit VICTOR apparatus but not conform to VICTOR's exacting standards. For your own protection, specify and use only VICTOR-made parts and accessories with your VICTOR apparatus.**

**Service or repair of VICTOR apparatus should be performed only by an authorized VICTOR repair technician. Improper service or repair, or modification of the product could result in damage to the product or injury to the operator.**

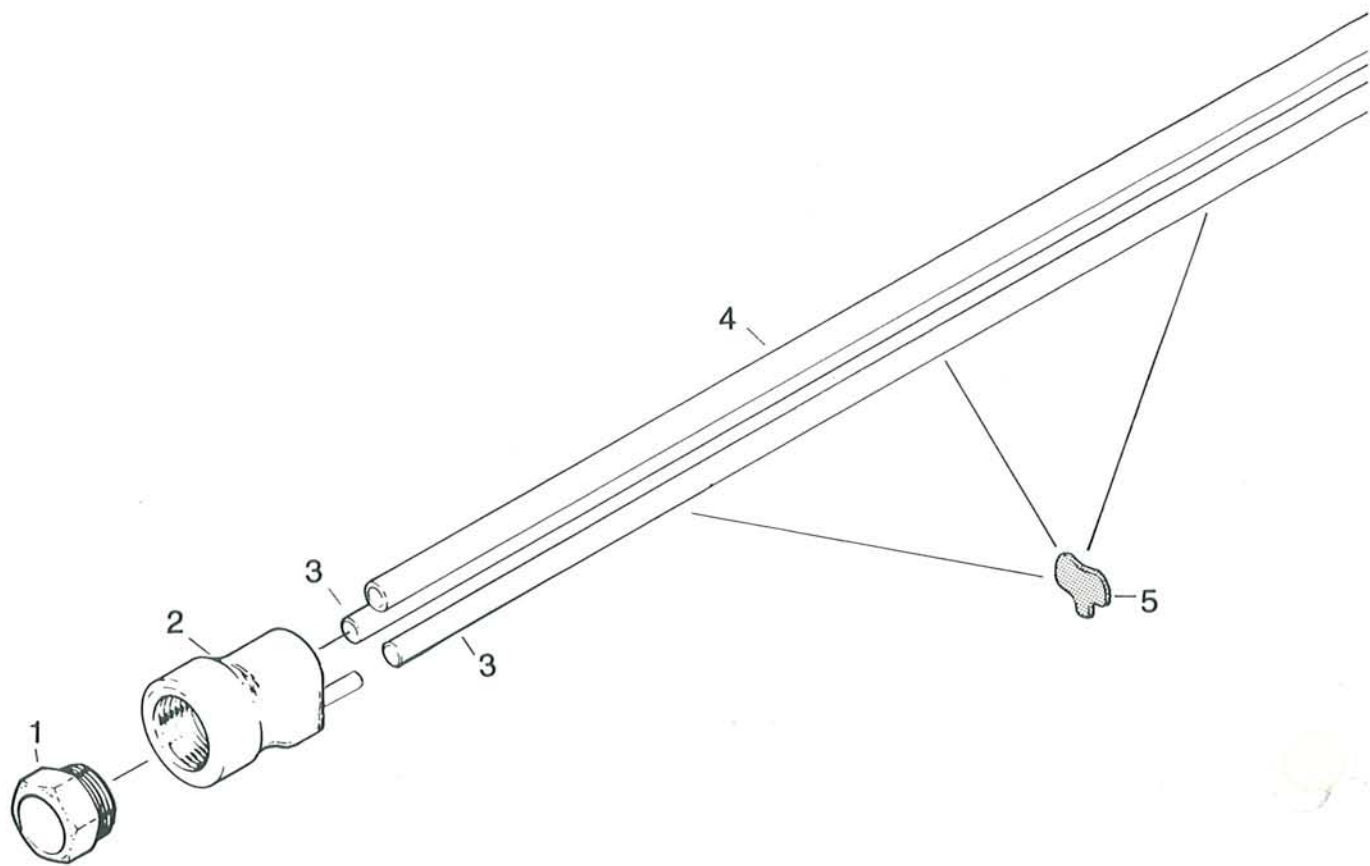
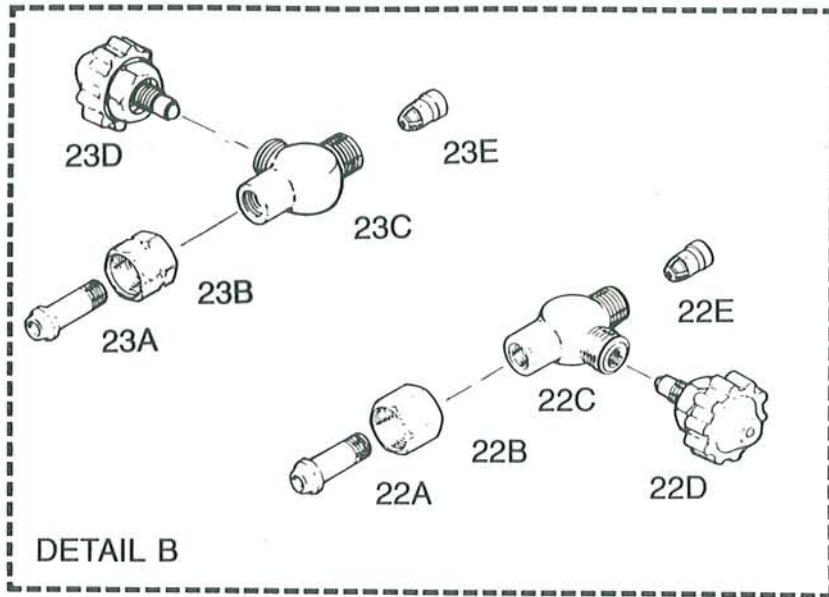

## PARTS LIST

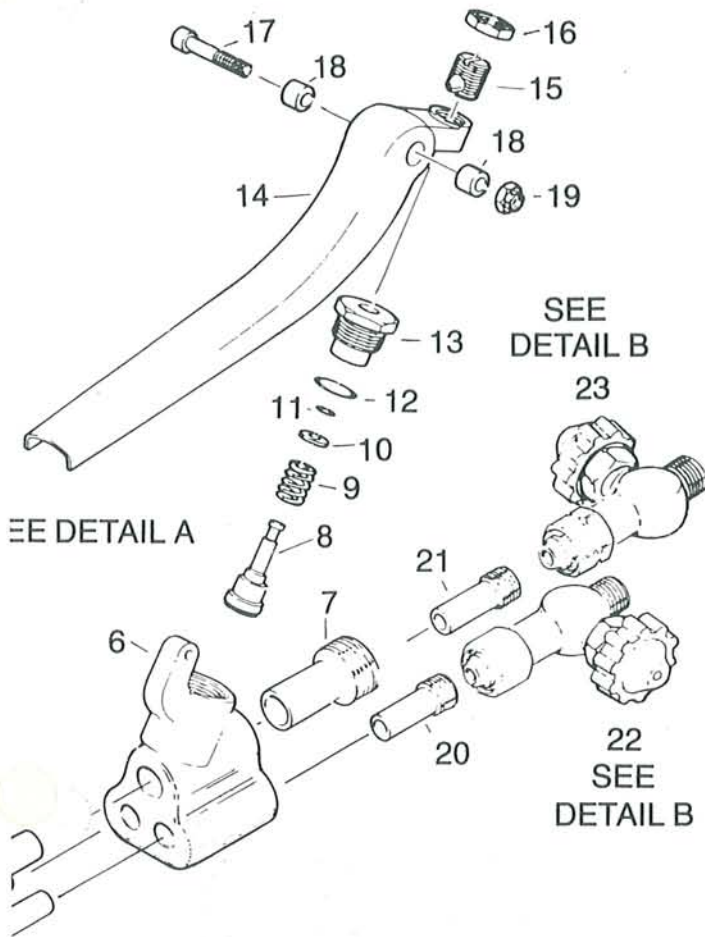

Ref. No.	Description	HC 1500C
*1	Tip Nut (1 5/16 - 18 UNEF)	0309-0074
**2	Head & Mixer Ass'y	0390-0054
3	Preheat Tube (2 req'd)	0303-0132
4	Cutting Oxy Tube	0303-0131
5	Tube Support (3 req'd)	0307-0053
6	Body	0301-0096
7	Adaptor	0965-0029
8	Seat Ass'y	0320-0096
8A	Seat Holder	0320-0097
*8B	Seat	0320-0098
8C	Cap Screw	1400-0137
*9	Valve Spring	0320-0071
*10	Washer	1406-0092
*11	O-Ring (Small)	1407-0013
*12	O-Ring (Large)	1407-0179
13	Valve Cap Nut	0320-0095
14	Lever	0307-0052
15	Valve Adjusting Screw	0320-0099
*16	Jam Nut	1409-0078
17	Cap Screw (10-24)	1400-0154
*18	Bushing (2 Req'd)	0314-0052
*19	Locknut (10-24)	1409-0062
20	Adaptor - Preheat Oxy	0312-0021
21	Adaptor - Preheat Fuel	0312-0022
22	Control Valve Ass'y-Oxy	0660-0239
22A	Swivel	0950-0133
22B	Nut	0902-0005
22C	Body w/Check Valve	0661-0233
22D	Valve Stem Ass'y	0662-0017
†22E	Check Valve	0652-0029
23	Control Valve Ass'y-Fuel	0660-0238
23A	Swivel	0950-0133
23B	Nut	0903-0004
23C	Body w/Check Valve	0661-0232
23D	Valve Stem Ass'y	0662-0017
†23E	Check Valve	0652-0029

\* Items most commonly required for Torch Repair and recommended for stock. Order Repair Kit P/N 0390-0041

† Order Internal Check Valve Kit P/N 0690-0027. Includes 2 Check Valves and Installation instructions. Special attention should be given to the notes on the front of this bulletin.

\*\* New Style Head — Identified by a narrow groove on bottom side.

See Back Page For Tip Information

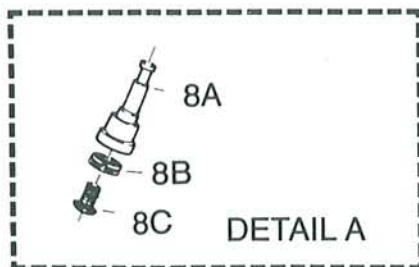

### SERIES 280N TIPS

TIP SIZE	.250	.312	.375	.437
Tip Ass'y	0336-0041	0336-0042	0336-0043	0336-0044
Shell	0338-0022	0338-0022	0338-0022	0338-0022
Internal Ass'y	0339-0008	0339-0009	0339-0019	0339-0012

### OPERATIONAL GUIDE

METAL THICKNESS	TIP MODEL NO.	TIP ORIFICE DIAMETER		OPERATING PRESSURE AT TORCH INLET — PSIG			CUTTING SPEED	GAS FLOW — SCFH		
		Fraction	Decimal	Cutting Oxygen	Pre-Heat Oxygen	Fuel Gas		Approx. In/Min.	Cutting Oxygen	Pre-Heat Oxygen
14" - 20"	.250-285 N	1/4"	.250	25 - 45	25 - 50	15 - 20	3 - 5	1500 - 2400	250 - 400	60 - 120
20" - 26"	.312-285 N	5/16"	.312	25 - 45	25 - 50	15 - 20	3 - 4	2300 - 3500	250 - 400	60 - 120
26" - 34"	.375-285 N	3/8"	.375	20 - 40	25 - 50	15 - 20	2 - 3	2300 - 3900	250 - 400	60 - 120
Over 34"	.437-285 N	7/16"	.437	20 - 40	25 - 50	15 - 20	1 - 3	2400 - 4500	250 - 400	60 - 120

**NOTE:** This chart should be used as a guide only. The many variables which surround heavy cutting operations make it impossible to formulate an accurate chart to fit all conditions. Trial cuts should always be made to determine exactly what pressures, speeds, and tip sizes are required.

### MAINTENANCE INSTRUCTIONS

#### CUTTING OXYGEN VALVE

The adjusting screw (Ref. #15) on the top of the cutting valve lever controls the cutting oxygen flow through the valve. To change the flow adjustment loosen the locknut (Ref. #16) holding the adjusting screw in place. Turn the adjusting screw clockwise to reduce flow, counter-clockwise to increase flow. When the desired flow is obtained, tighten the locknut. Be sure to align screwdrive slot in adjusting screw to run parallel to tubes at final adjustment. If leakage develops through the cutting valve, replace the seat holder assembly (Ref. #8).

**NOTE:** Before replacing seat holder assembly inspect the seating surface in torch body for rough surfaces. If necessary re-surface with high pressure valve seat reamer.

If leakage is around the valve stem, replace the stem "O" ring seal. Proceed as follows to replace these parts.

- a. Remove cutting lever nut (Ref. #19), retaining lever cap screw (Ref. #17) and lever bushings (Ref. #18) from lever (Ref. #14). Remove lever from torch.
- b. Unscrew locknut (Ref. #16) from cutting valve lever (Ref. #14) and turn adjusting screw (Ref. #15) clockwise far enough to allow handle to be removed from valve stem.
- c. Unscrew valve cap (Ref. #13) and carefully remove the cutting valve assembly.
- d. Slide seat holder assembly out of the valve cap and remove "O" ring (Ref. #12) from cap nut. Discard the "O" ring.
- e. Remove the "O" ring seal (Ref. #11), washer (Ref. #10) and valve spring (Ref. #9) from the seat holder assembly. Discard the "O" ring and felt washer.
- f. Carefully clean and examine seat holder assembly, valve cap, spring, locknut and adjusting screw for damage and excessive wear. Replace parts as necessary and re-assemble.  
**NOTE:** Be sure to lubricate "O" rings before re-assembly.
- g. Install the adjusting screw (Ref. #15) in the lever (Ref. #14) with the opening visible on bottom side. Position opening over the valve stem. Turn counterclockwise 2-3 times.
- h. Loosely assemble the lever (Ref. #14), bushings (2), retaining screw and nut. Maximum flow is achieved at 3/32 (.093) lift of the seat. Adjust the screwdriver slot accordingly. Secure lock nut.

**NOTE:** Slot in adjusting screw must be parallel with torch at final adjustment. Tighten lock nut (Ref. #19).

