

OPERATOR'S MANUAL AND SAFETY INSTRUCTIONS

WITH INSPECTION AND MAINTENANCE INSTRUCTIONS
MAGNET SPECIFICATIONS:

Type: SCRAPMASTER

Size: 57" D

Part No.: 46-405700

Volts D.C.: 230

Nom. Amps @ 20° C: 75

Nom. Ohms @ 20° C: 3.06

Max. Duty Cycle: 75%

Magnet Weight: 4,400 LBS

Lift Capacity:

#1 HEAVY MELTINGS: 2,700 LBS

#2 HEAVY MELTINGS: 1,800 LBS

STEEL TURNINGS: 850 LBS.

Performance will vary due to specific operating conditions.

DATE: 10-30-08

MANUAL: 46-405700

Rev.

with DD-12288 Rev. H



O.S. WALKER CO. INC
WALKER NATIONAL, INC
WALKER MAGNETICS NATIONAL, Ltd.

 **DANGER**

- Always stay clear of the load.
- Never lift loads over people or in close proximity to people.
- Never attempt to operate this magnet until you have read and understand this Operator's Manual.

CONTENTS

MAGNET SPECIFICATIONS	1
INTRODUCTION	3
SAFETY INSTRUCTIONS	4
GENERAL SAFETY RULES	4
RECOGNIZE SAFETY INFORMATION	5
WAYS TO AVOID A REDUCTION OF LIFTING CAPACITY	5
ADDITIONAL WARNINGS	6
ASME B30.20 "Below-the-Hook Lifting Devices"	6
<i>CLOSE PROXIMITY OPERATED LIFTING MAGNET</i>	6
<i>REMOTELY OPERATED LIFTING MAGNET</i>	6
CONNECTING THE ELECTRIC POWER	7
INSTALLATION INSTRUCTIONS	7
BEFORE INSTALLING THE LIFTING MAGNET and/or MAGNET SYSTEM	7
ELECTRICAL DISCONNECTS	8
ELECTRICAL GROUNDING	8
TYPICAL GENERATOR SCHEMATIC	9
MAGNET SUPPRESSION	9
TYPICAL RECTIFIER SCHEMATIC	9
SAFETY HOOK LATCH	10
CABLE TAKE UP REEL	10
CABLE STRAIN RELIEF	10
ESTABLISHING TEST VALUES	10
IMPORTANT FACTS FOR THE OPERATION OF LIFT MAGNETS	11
SAFETY RULES	13
LIFTING PROCEDURES Do's & Don'ts	14
INSPECTION AND MAINTENANCE INSTRUCTIONS	15
FREQUENT INSPECTION (Daily to Weekly) depending on severity of service	15
PERIODIC INSPECTION (Monthly to Yearly) depending on severity of service	15
PERIODIC INSPECTION RECORD FORM	16
MAGNET INSPECTION (Out of Service Magnet)	16
YEARLY MAGNET INSPECTION	16
TROUBLE SHOOTING	17
<i>MAGNET TEST PROCEDURES</i>	17
REPLACEMENT PARTS LIST (See attached page)	18
RETURN AND REPAIR INSTRUCTIONS	19

INTRODUCTION

Thank you for purchasing this O.S. Walker Product. If used and maintained properly, it should serve you for many years. Thousands of O. S. Walker lift magnets are in service today doing safe, fast, and efficient magnetic material handling applications. It is often the only way for one person to load, transport, and unload material.

Walker Products have proven to be among the best designed and safest in our industry. However, if used improperly, any **CER** magnet can be rendered inefficient and unsafe. Therefore, it is absolutely essential that anyone who uses this lifting magnet and is responsible for its application be trained on how to use it correctly.

READ THIS MANUAL CAREFULLY TO LEARN HOW TO OPERATE AND MAINTAIN YOUR MAGNET. FAILURE TO DO SO COULD RESULT IN SERIOUS INJURY OR DEATH, TO YOURSELF AND PEOPLE IN THE AREA.

THIS MANUAL SHOULD BE CONSIDERED A PERMANENT PART OF YOUR MAGNET AND SHOULD ALWAYS BE AVAILABLE TO ALL OPERATORS AND REMAIN WITH THE MAGNET IF IT IS RE-SOLD.

**Additional copies of this OPERATOR'S manual ARE AVAILABLE JUST CALL
1-800-962-4638 AND REQUEST ADDITIONAL COPIES OF MAUAL #37-DD12288..**

SAFETY INSTRUCTIONS

GENERAL SAFETY RULES

Danger always exists when loads are transported by lifting devices, especially when the equipment is not being used properly or is poorly maintained. Because accidents and severe bodily injury or death can result, special safety precautions apply to the operation, inspection, and maintenance of the Walker Lift Magnets.

Following these simple rules can help to avoid lifting accidents:

⚠ DANGER

- **Always** stay clear of the load.
- **Never** lift loads over people or in close proximity to people.
- **Never** attempt to operate this magnet until you read and understand the Operator's Manual.
- **Never** use this magnet to lift, support or transport people.
- **Never** leave any lifted load unattended.
- **Never** lift more than one work piece at a time with this magnet.
- **Always** make sure that the supporting structure and load attaching devices (i.e. crane, chains and hook) are rated to support the weight of the magnet and load.
- **Always** make sure that the load's weight and dimensions are within the Magnet's Lifting Guidelines. These Guidelines are located in the Operator's Manual.
- **Always** let those near you know that a lift is to begin.

Remember, proper lifting knowledge and techniques are the responsibility of the operator. Be sure to read and understand the instructions and safety warnings contained in this manual before using your lifter.

If you do not understand everything in this manual contact O.S. Walker for assistance before using the magnet.

Call 1-800-W-MAGNET |

SAFETY INSTRUCTIONS

RECOGNIZE SAFETY INFORMATION



This is the safety alert symbol. When you see this symbol on your magnet or in this manual, be alert to the potential for personal injury. Follow recommended precautions and safe operating practices at all times.



DANGER

Red Background, White Letters

This indicates a situation in which a hazard is imminent and will result in a high probability of serious injury or death.



WARNING

Orange Background, Black Letters

This indicates a potentially hazardous situation, which could result in some probability of serious injury or death.



CAUTION

Yellow Background, Black Letters

This indicates a potentially hazardous situation, which could result in minor injury or moderate injury.

*These are
Hazard
Seriousness
Signal
Words*

WAYS TO AVOID A REDUCTION OF LIFTING CAPACITY



DANGER

To Avoid any Reduction of Lifting Capacity:

- The lifting surfaces of the magnet and the area of the load where the magnet will be located must be clean, smooth, flat and free of nicks and burrs.
- The full area of the magnet's lifting surface must be in contact with the load.
- The load must be at least as thick as half the radius of the center pole, or the thickness of the side pole on a rectangular magnet.
- The load must be low carbon steel such as SAE 1020.
- The magnet's lifting surface must stay level and the contacting surface of the load must remain flat.
- The temperature of the load must not be greater than 110°F (43°C) unless the magnet is designed for hot applications.
- The control actuator must be fully in the "on" or "lift" position.
- Do not exceed the magnet duty cycle. Exceeding the duty cycle will result in reduced lifting capacity.
- Repair or modification of this magnet should only be done by the O. S. Walker Co.*

* Walker replacement parts may be installed by a ****Design Person**.

**** Designated Person** - A person selected or assigned by the employer as being competent to replace specific replacement parts listed in this manual and is able to verify the proper functioning of the specific replacement parts and the entire product after the completion of the installation.



WARNING

If you have any difficulty lifting a load, **DON'T LIFT IT!**
Call Walker for advice at 1-800-962-4638

SAFETY INSTRUCTIONS

ADDITIONAL WARNINGS

⚠ WARNING

- **Never** operate a magnet with a direct electrical short to the magnet case. Any person making contact with such a magnet could receive a severe electrical shock.
- **Always** use safety latches on all crane and hoist hooks.
- **Never** operate damaged or malfunctioning magnets.
- **Never** remove or damage operating and warning labels.
- **Persons** using pacemakers or any other medical devices should not use this magnet until they have consulted with their physician.

⚠ WARNING

- Disassembly or repair of this magnet can result in reduced holding power and/or cause an unsafe condition. Therefore, anytime the magnet system is disassembled beyond the parts list shown in this manual, and the magnet is being used as a close proximity operated lifting magnet, the magnet must be re-tested for breakaway force in accordance with the test described in ANSI/ASME B30.20.
- Electrical power interruption to Electromagnets *, will cause the load to drop with a risk of injury to anyone in close proximity to the operating area of the magnet.
- Modification of any operating mechanism or structure of this magnet can reduce the magnet's effectiveness and/or cause unsafe conditions.

* ElectroPerm magnets are not affected by Electrical power interruptions once they have been turned on and are fully charged.

ASME B30.20 “Below-the-Hook Lifting Devices” safety standard¹

Walker lifting magnets are manufactured in accordance with ASME B30.20 “Below-the-Hook Lifting Devices” safety standard. This American National Standard covers the construction, installation, operation, inspection, and maintenance of Close Proximity Operated Lifting Magnets and Remotely Operated Lifting Magnets.

CLOSE PROXIMITY OPERATED LIFTING MAGNET

A magnetic lifter is considered a close proximity lifting device if:

- A. The operator of the magnetic lifter is required to manually position the lifter on the load, and/or manually guide the load during its movement.
- B. The magnetic lifter is remotely controlled and operated in close proximity to people.

REMOTELY OPERATED LIFTING MAGNET

A lifting magnet is considered a remotely operated lifting magnet only if persons shall not be in close proximity to an energized remotely operated lifting magnet, except for electrical testing.

For further information, refer to ASME B30.20 Section 20-3 for Close Proximity Lifting Magnets and 20-4 for Remotely Operated Lifting Magnets.

¹ The American Society of Mechanical Engineers, Three Park Avenue, New York, NY 10016-5990

INSTALLATION INSTRUCTIONS

BEFORE INSTALLING THE LIFTING MAGNET and/or MAGNET SYSTEM

1. Unpack the lifting magnet and/or magnet system and check that all components have been included and are undamaged after shipment.
2. Observe all instructions and warnings in this manual and on the magnetic lifter.
3. If you do not understand everything in this manual contact Walker for assistance before using the magnetic lifter.
4. Check that the load rating of the hoisting equipment exceeds the total weight of the load plus the weight of the magnetic lifter.
5. If the magnetic lifter is to be installed on an existing crane, hoist, or other type hoisting equipment, move it to a location where it will cause the least interference with other equipment and operations in the area.
6. Then place all power controllers in the “**OFF**” position.

Remember, only qualified personnel should install this lifting magnet and/or magnet system.

CONNECTING THE ELECTRICAL POWER

WARNING

- All electrical wiring should be installed by a qualified electrician and must conform to national, state /province and local electrical codes.
- Prior to beginning installation, check that all sources of power are disconnected, locked out, and tagged “out of service”
- Determine the voltage and current rating of the magnetic lifter. This information is marked on the magnet or system’s nameplate.

CONNECTING THE ELECTRICAL POWER ELECTRICAL DISCONNECTS

(In accordance with the ASME B30.20² safety standards)

- A separate Magnet circuit disconnect switch, independent of the hoisting equipment's disconnect switch, shall be provided. The Magnet circuit disconnect switch must be of the enclosed type with provision for locking, flagging, or tagging in the open (off) position and have means for discharging the inductive energy of the magnet. The Magnet circuit disconnect switch must be connected on the line side (power supply side) of the hoisting equipment disconnect switch.
- Power supplied to magnets from DC Generators can be disconnected by disabling the external powered source connected to the DC generator, or by providing a circuit switch that disconnects excitation power to the generator and removes all power to the magnet.
- Disconnects are not required on externally powered electromagnets operating from a 120 V AC single phase power source.

ELECTRICAL GROUNDING

- All Walker electromagnetic lifting magnets are provided with provisions to ground the electrically conductive body of the magnet in order to facilitate compliance with the governing electric codes.

WARNING

- Because Walker does not know the individual applications of all its lifting magnets, each magnet is supplied with a safety ground wire or a grounding lug for attachment of a safety ground wire. The green or green with yellow stripe safety ground wire provided with most magnets is attached to the body of the magnet.
- It is the responsibility of the electrical installer to verify that the magnet is electrically wired and grounded properly and in accordance with the local and national electric code for the intended application.
- In the USA, the governing national standard is the National Electric Code NFPA 70. Article 250 contained in this code is devoted to the grounding requirements for various types of installations.
- Prior to energizing the electromagnetic device, check all the electrical connections and confirm that the metal body of the electromagnetic device is electrically grounded.

² The American Society of Mechanical Engineers, Three Park Avenue, New York, NY 10016-5990

INSTALLATION INSTRUCTIONS

TYPICAL GENERATOR SCHEMATIC

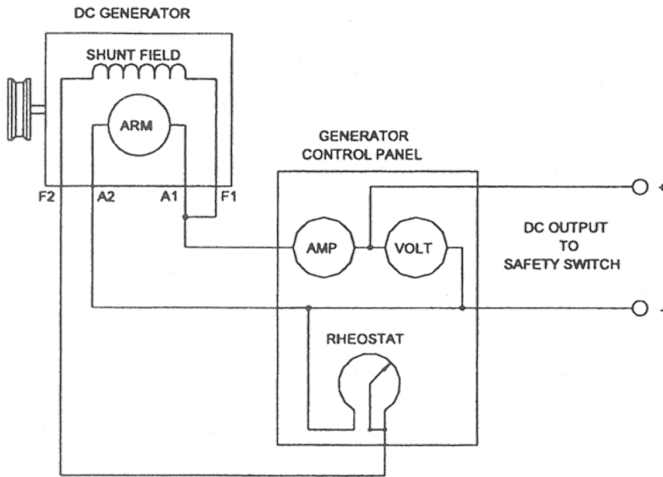

Connections on generator shown for C.C.W. rotation facing commutator end. Interchange field connections for clockwise rotation.

Eliminate control panel by connecting F2 to A2. Voltage will then be controlled by generator RPM only.

TYPICAL RECTIFIER SCHEMATIC

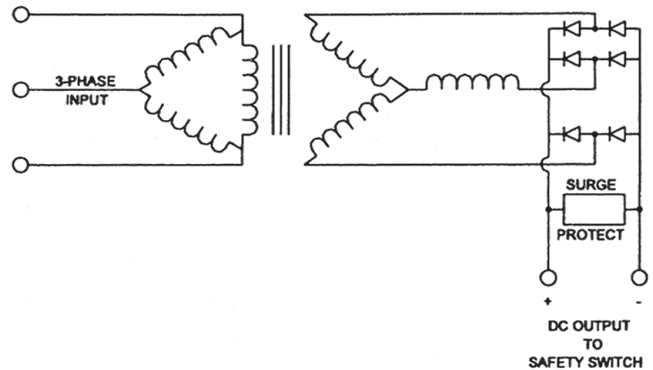

Rectifier must be rated for magnet service and be equipped with surge protection.

Rectifier may have options such as: AC circuit breaker, AC line contractor, DC metering, Indicator lights, fuses or circuit breakers, which are not shown above.

MAGNET SUPPRESSION

When energized, an electromagnet creates a large magnetic field and the magnet coil contains large amounts of energy. Capacitive discharging occurs when a magnet coil dissipates its energy internally. When the current producing source is removed from an inductive device, such as the coil of a magnet; the energy stored in the inductor produces work in order to bring the system into equilibrium. In the case of a magnet coil, when the source of power is removed, the voltage potential between one end of the coil and the other increases rapidly, and if a suitable median exists, the electrons flow from one end to the other through the median. In other words, the movement of electrons, from one end of the coil to the other, over or through the conductor, is the work produced by the stored energy. The energy stored in a magnet coil is normally controlled through external circuitry usually located in the electrical magnet controller. Walker controls employ a suppressor/resistor network across the magnet to accomplish this. If a control other than a Walker control is to be used, ensure that the controller provides adequate suppression. Adequate suppression is defined as any circuit, which provides a continuous current path. For technical assistance, contact your Walker representative.

SAFETY HOOK LATCH



⚠ WARNING

Always use a safety hook latch on your crane hook to hold your magnet.

CABLE TAKE UP REEL

A cable take-up reel is recommended on boom type and overhead type cranes to control the cables in the air between the crane and magnet. Cable take-up reels are not normally required on hydraulic type cranes.

CABLE STRAIN RELIEF

With electrical power off, connect power supply cable to the line side terminals of connectors. Power supply cable should be supported in a vertical position to prevent cable damage. Recommended installations for overhead and mobile cranes are illustrated above. O.S. Walker's CSR-73 cable strain relief assembly can be used in these applications and are recommended for all applications to eliminate strain on the terminal connections.

ESTABLISHING TEST VALUES

To obtain accurate values, the Coil Resistance Test, Megger Test, and AC Current Test should be performed on a magnet immediately upon receipt from the manufacturer. The values obtained from these tests should be recorded and compared with subsequent test results.

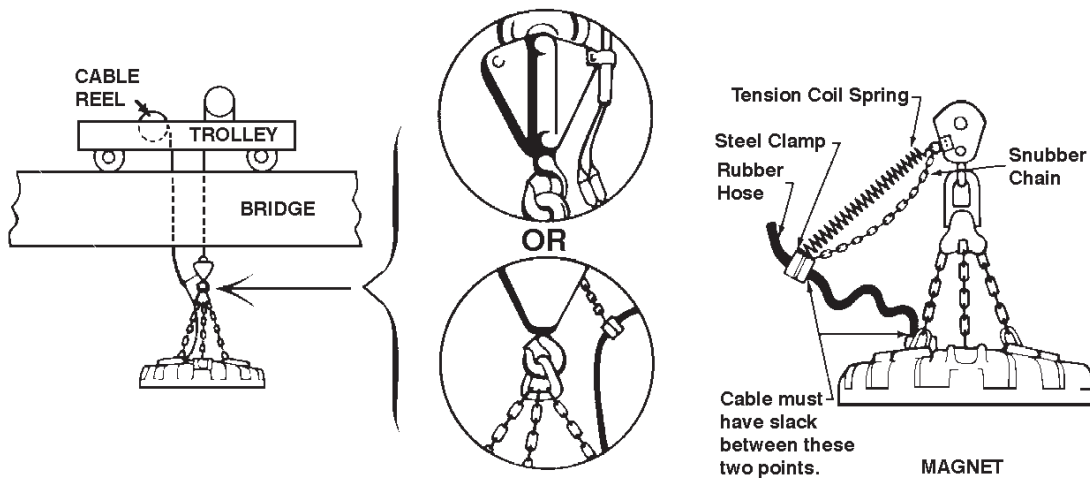

IMPORTANT FACTS FOR THE OPERATION OF LIFT MAGNETS

LOAD CHARACTERISTICS OTHER THAN JUST WEIGHT
MUST BE CONSIDERED IN ORDER TO DETERMINE
THE LOAD THAT ANY MAGNET CAN LIFT.

This statement is true for all lifting magnets because they all operate using the same fundamental laws of physics. Magnetic power is often pictured as lines of magnetic force flowing from north pole to south pole. Anything that limits the flow of these magnetic lines of force obviously reduces the magnet's lifting capacity. There are many important factors, which limit the flow of these lines of force.

1. SURFACE CONDITIONS

Magnetic lines of force do not flow easily through air. They need iron in order to flow freely; therefore, anything that creates a space or an air gap between a magnet and the load limits the flow of magnetic lines of force and, thus, reduces the lifting capacity of a magnet.

- **Magnet's Lifting Surface Condition** — The lifting surfaces of a magnet must be clean, smooth, flat and free of nicks and burrs to minimize the air gap between a magnet and the load. Most magnets are designed with soft, low carbon steel lifting surfaces in order to maximize the lifting capacity; therefore, special care must be taken to protect these surfaces. Some magnets have hard coatings applied to the lifting surfaces in order to reduce wear. However, this reduces the lifting capacity.
- **Load Surface Condition** — Paper, dirt, rags, rust, paint and scale act the same as air. Also, a rough surface finish on the load creates an air gap between the magnet and load. Any of these conditions will reduce the magnet's lifting capacity.

2. LOAD THICKNESS

The greater the number of lines of magnetic force flowing from a magnet into the load, the greater the effectiveness of the magnet. The thicker the load, the more lines of magnetic force are able to flow. After a certain thickness of load, no additional lines of force will flow because the magnet has reached its full capacity.

- The maximum thickness of load required to reach full lifting capacity is approximately half the radius of the center pole for a round magnet or the thickness of the side pole on a rectangular magnet.
- The shape and density of a load and the amount of the load in direct contact with the pole faces of the magnet all affect the final lifting capacity.
- Thin material (load) means less iron available, and thus fewer lines of magnetic force flow from the magnet into the load. Therefore, the lifting capacity of the magnet is reduced. In some cases, the magnet(s) will attract more than one thin plate of material when set on a stack of thin plates. Use extreme care in these types of applications since the lower plate may not be held sufficiently.

3. LOAD ALLOY

Low carbon steels, such as SAE 1020 steel, are nearly as good conductors of magnetic lines of force as pure iron. However, many other alloys contain non-magnetic materials, which reduce the ability of magnetic lines of force to flow into the load. An alloy such as SAE 300 series of stainless steel is almost as poor a conductor of magnetic lines of force as air.

- Type 416 stainless steel is considered magnetic, but it contains enough chromium so that a magnet can develop only half as much force on a Type 416 stainless steel load as it can on a SAE 1020 steel load. Also, because of the carbon content, the force developed on cast iron is less than one-half of that developed on SAE 1020 steel. (Chilled cast iron further reduces the force to less than one quarter.)

4. LOAD LENGTH OR WIDTH

As the length or width of a load increases, it ceases to remain flat when lifted and the edges begin to droop. This drooping or sagging of the load can create an air gap between the load and the magnet. This is called peel. If this occurs, the lifting capacity of the magnet is greatly reduced.

5. POSITION OF MAGNET'S LIFTING SURFACE

As the position of the magnet's lifting surface changes from horizontal to vertical, the lifting capacity of the magnet decreases. When the magnet's lifting surfaces are vertical, the lifting capacity of the magnet is minimum and dependent upon the coefficient of friction between the magnet's lifting surface and the load.

6. PORTION OF MAGNET SURFACE IN CONTACT WITH LOAD

The full surface of the magnet must contact the load if the magnet is to achieve rated lift capacity.

7. LOAD TEMPERATURE

The temperature of the load can cause damage to the magnet and, if high enough, can even change the magnetic characteristics of the load. For standard lift magnets, Walker should be consulted if the load or air temperature exceeds 110° F (43° C).

SAFETY RULES

1. **Never attempt to operate this lifting magnet until you read and understand this Operator's Manual & Safety Instructions.**
2. Check the condition of your entire magnet(s) by visually inspecting it prior to use each day. Especially check the chains and pins for any defects and wear.
3. Check that the weight and size of the load to be lifted does not exceed the rated lift capacity of the magnet, magnet lifting system, or the crane.
4. Position the magnet(s) on the load so that it will remain level when lifted.
5. For maximum performance, the full surface of the magnet must be in contact with the load before being energized. Energize the magnet(s) by placing the control actuator in the "on" or "lift" position. To obtain maximum lift, allow a few seconds for the magnet(s) to reach full power before lifting the load.
6. Check to be sure no one is near the load to be lifted. **FOR CLOSE PROXIMITY OPERATIONS:** Inform others in the area that a lift is to begin. Lift the load 2 to 3 inches (50 to 77 mm) and then jar the load to ensure that adequate holding power is available. Always stay clear of the load.
7. Lift and move the load **SMOOTHLY**. Avoid jarring and swinging the load. **KEEP THE LOAD LEVEL. NEVER** let the load come in contact with any obstruction.
8. **FOR CLOSE PROXIMITY OPERATIONS: ALWAYS STAY CLEAR OF THE LOAD. IF YOU MUST GUIDE THE LOAD,** push or pull the edges. This keeps your entire body clear of the load at all times. **DO NOT** guide the load by pushing or pulling the magnet(s). **NEVER** get in a position where you could get hit with the load if it dropped.
9. Carefully set the load down and de-energize the magnet(s) or release scrap material as required. Apply reverse current as required for a clean release. Lift the magnet(s) slightly to be sure the load has been released.
When working in an area using lifting magnets, wear safety glasses, work gloves, safety shoes, and a safety hat.

WARNING

NEVER re-energize the magnet(s) until it has been placed in contact with the next load to be lifted. Prematurely energizing the magnet could cause damage to the magnet(s), as well as cause unwanted materials to be accidentally attracted to the magnet. This could cause personal injury to people in the vicinity.

GENERAL OPERATING INSTRUCTIONS & TROUBLE SHOOTING

LIFTING PROCEDURES Do's & Don'ts

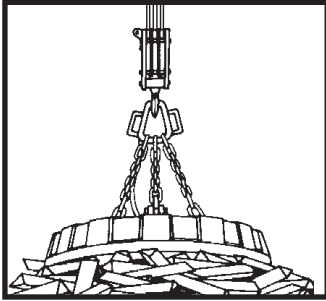

TURN ON POWER - WAIT A FEW SECONDS - THEN LIFT

This lets magnetism build to a peak level and gives a maximum load to your lift. you'll move a bigger payload faster.

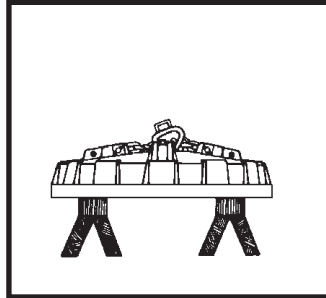

KEEP MAGNET DRY

Always store magnet off of the ground. Never cool the magnet with water. Store in dry area - moisture can cause short circuits thereby crippling lifting capacity.

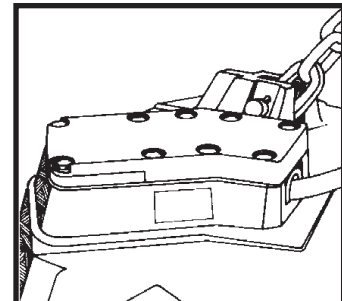

KEEP TERMINAL BOX CLOSED

This keeps moisture away from the terminals and out of the magnet coil..

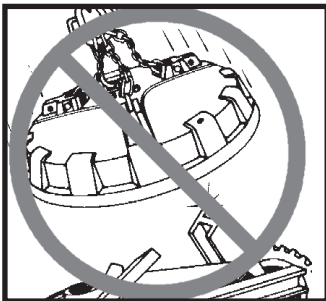

ALWAYS SET MAGNET DOWN EASY

Ease your magnet down onto the material. Repairs are costly and lost valuable time means less profits.

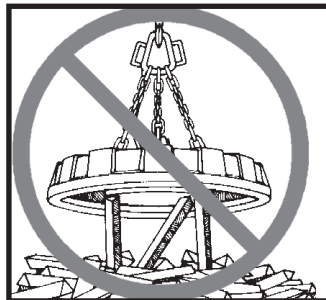

KEEP POWER OFF UNTIL MAGNET SETTLES ON LOAD

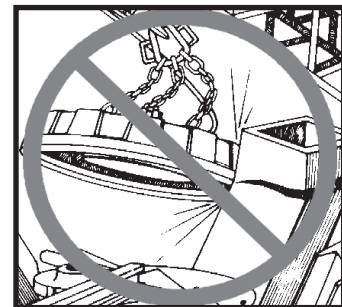

DON'T USE YOUR MAGNET AS A BATTERING RAM

Improper use, such as dropping a magnet to break up heavy pieces for scrap will cause damage to the pole shoe, terminal box, or damage the coil. Use the magnet only for lifting.

DO NOT EXCEED THE DUTY CYCLE RATING OF THE MAGNET.

(Exceeding the duty cycle will result in reduced lifting capacity because of the excessive heat that will be built up in the magnet.) Duty cycle rating (D.C.%) is defined as: $\{\text{Time On} \times 100\} / \{\text{Time Off} + \text{Time On}\} = \text{D.C.}\%$ and is expressed as a percent. With a maximum of 10 minutes Time On to avoid overheating the magnet.

To maximize the effectiveness of your magnet(s), keep power off when the magnet(s) are not in use.

EXAMPLES:

3 minutes on, 1 minute off equals: $\{3 \times 100\} / \{3 + 1\} = 75\%$

5 minutes on, 5 minutes off equals: $\{5 \times 100\} / \{5 + 5\} = 50\%$

The duty cycle rating of your magnet(s) is marked on the magnet nameplate.

INSPECTION AND MAINTENANCE INSTRUCTIONS

FREQUENT INSPECTION (Daily to Weekly) depending on severity of service

1. TURN OFF ELECTRIC POWER.

2. All chain links should be checked for wear. Any chain in which the minimum diameter of the worn portion of any link is less than 87% of the actual new stock diameter or thickness must be replaced. Never attempt to repair links by welding or hardfacing worn areas.
3. Inspect all chain pins. Any pin in which the minimum diameter of the worn portion is less than 90% of the new stock diameter must be replaced. Be sure that cotter pins, plates, washers, etc. are in place and in good condition.
4. Check the entire magnet case for any cracks. Repair cracks immediately.
5. Check chain pin lugs and tagline lugs for wear and other damage. Make necessary repairs immediately.
6. Inspect the physical condition of all electrical cables and leads. Look for cuts, abrasion and strain damage. Replace any suspect cable or lead. Magnet leads are sometimes protected by thick hoses, steel pipes, or fabricated cable channels. Check that these items have not been cut, bent or crushed, and hiding a damaged cable or lead.
7. Check the terminal box for any damage or missing components. Replace any missing covers and plugs to prevent the entry of moisture. Clean away any build-up of dirt or foreign materials in the area of the box since these materials retain moisture and can accidentally enter the box during repairs.
8. Inspect the non-magnetic bottom plate for cracks, dents, and the integrity of the weld between it and the magnet case.
9. If the magnet has a center pole shoe, inspect for excessive wear, cracks and fit to the center pole. An air gap between the shoe and pole will result in reduced lifting capacity.
10. If the magnet is used for plate lifting, care should be taken to keep the unpainted magnetic pole surfaces on the bottom of the magnet flat and free from rust, nicks and burrs, which reduce the lifting capacity. Burrs may be removed by filing, deep nicks may require grinding of the pole faces.

PERIODIC INSPECTION (Monthly to Yearly) depending on severity of service

1. TURN OFF ELECTRIC POWER.

2. Completely inspect and **record** the condition of the magnet and its suspension system and maintain this record. Test and record the magnet's coil resistance, case to coil resistance and AC current test reading. This will provide a health status of the magnet's internal insulation when compared with values taken when the magnet was put in service.

PERIODIC INSPECTION RECORD FORM

Record date and initials; note condition of each item*

Date and Initials for each inspection	Condition	Date	Initials	Date	Initials
Structural & Welding Condition					
Chains					
Lift Bail					
Lift Pin					
Lift Lugs					
Fasteners					
Magnet Face					
Coil Shield					
All electric components incl. meters, indicators, or alarms shall be tested for proper operation.					
Labels & Safety Instructions					
Magnet Electrical Tests					
Coil Resistance (ohms)					
Case to Coil Res. (meg ohms)					
AC Current Test (amps)					

* **Make additional forms as needed.**

MAGNET INSPECTION (Out of Service Magnet)

Any magnet that has been out of service more than 30 days **MUST** be thoroughly inspected before being put back into service.

YEARLY MAGNET INSPECTION

Walker recommends that your Close Proximity Lifting Magnet be re-tested for breakaway force each year.

Contact O.S. Walker for test instructions or re-certification.

TROUBLE SHOOTING

In many cases of poor magnet performance, the difficulty can be traced to the power supply, controller, or cable reel assembly. If these elements are found to be in good working order the magnet can be checked with the following simple tests.

If a lifting magnet is suspected to be faulty, preliminary electrical tests can be made from the external leads.

1. Disconnect power to the magnet before making any electrical tests on your magnet.
2. Make electrical tests at outside leads. If tests indicate an open coil, ground or low case to coil resistance, disconnect cable and connector and make further tests at coil leads. On some magnets, this will require removal of the terminal box cover. If these tests are satisfactory, trouble is then in the outside leads, connectors, controller, or power supply.

DANGER

Use extreme care when opening a magnet's terminal box. Contents may be under extreme pressure. Allow magnet to cool to ambient temperature before opening terminal box.

MAGNET TEST PROCEDURES

(These tests should be done when the magnet temperature is close to ambient temperature (70° F) and has not been operated for at least 10 hours).

COIL RESISTANCE TEST

1. Use a Wheatstone Bridge, Kelvin, or other accurate ohmmeter (e.g., Simpson model 1699 milliohmmeter).
2. Connect meter leads to terminal junction. If the resistance is lower than that shown on the magnet's nametag or by calculating the coil resistance by dividing 230 volts by the amps on the nametag, shorted turns are indicated. If the resistance is less than 75% of this resistance, DO NOT operate magnet, as it is likely to cause extreme overheating and may cause serious damage to the coil material.

GROUND INSULATION TEST "MEGGER TEST" (Case to Coil Resistance)

1. Use a 500-volt Megger (e.g., Biddle Major Megger Tester).
2. Connect one Megger lead to terminal junction and the other to a clean surface of the magnet casing. If the reading is between 20 Megohms and infinity, it is typical of a brand new Walker magnet. If the reading is between 10 & 20 Megohms, the insulation is sound. If the insulation is between 1 and 10 Megohms, the insulation is still acceptable. However, the insulation has degraded and the magnet should be closely monitored for further deterioration. If the reading is less than 1 Megohm, it should be returned to the factory for further inspection. Zero Megohms indicates a dead short.

WHAT CAN AFFECT THE GROUND INSULATION TEST (Case to Coil Resistance)

1. The most common cause is moisture.
 2. The most likely entry point is the terminal box because the box has not been properly maintained and sealed.
 3. The second most likely entry point is the bottom plate area because the bottom plate has been damaged and the welds have fractured.
- Once the moisture enters the coil cavity, the coil insulation degrades and permits the current to arc or trace through the moisture to the case.

AC CURRENT TEST

A more accurate test for shorted turns can be made by checking the current that will flow through the magnet with a 220 volt 60 cycle power supply connected to the magnet leads. A good quality ammeter should be used to perform this test. To establish a value, which can be used in a comparison with future readings, this test should be performed on the magnet upon receipt from the manufacturer. If provided with the serial number of the magnet, Walker can supply you with the results of the pre-shipment AC Current Test. Future test readings, which are higher than the initial test value, indicate that additional shortened turns are present.

If all tests meet the magnet specifications, the problem can be:

1. Low Voltage
2. Controller Trouble
3. Cable Reel - Ground or Shorts
4. Worn or Broken Cable

REPLACEMENT PARTS LIST (See attached page)

RETURN AND REPAIR INSTRUCTIONS

For warranty and non-warranty repairs on any part of your magnet system, contact O.S. Walker, Inc. TOLL FREE at 1-800-W-MAGNET. A return authorization number will be issued along with any applicable packaging and shipping instructions. After receipt of the components to be repaired, O.S. Walker, Inc. will perform an inspection and provide an estimate of the repair costs at no charge to the customer. Authorization from the customer must be obtained by O.S. Walker, Inc. before repairs are made. Transportation charges, both to and from the factory, are the sole responsibility of the customer.

ALWAYS STAY CLEAR OF THE LOAD

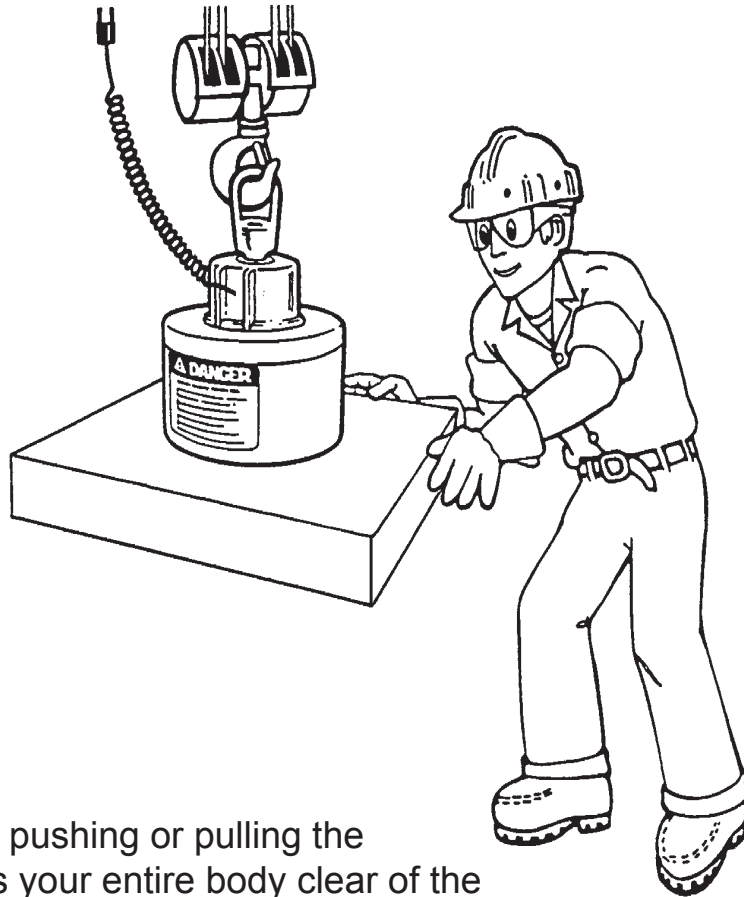

Guide the load by pushing or pulling the edges. This keeps your entire body clear of the load at all times.

DO NOT guide the load by pushing or pulling the magnet. NEVER get in a position where you could get hit with the load if it is dropped.

FOR FAST RESPONSE, CALL 1-800-W-MAGNET

WALKER

O.S. WALKER

Rockdale Street, Worcester, MA 01606
(508) 853-3232 FAX (508) 852-8649
1-800-W-MAGNET
3508 Glenridge Drive, Chino Hills, CA 91709
(909) 597-4785 FAX (909) 597-0581

WALKER MAGNETICS NATIONAL, LTD.

901 Arvin Avenue, Stoney Creek, Ontario, L8E5N9 Canada (905)643-3338
In Canada: 1-800-267-4678 FAX (905) 643-6111

WALKER NATIONAL, INC.

2195 Wright Brothers Avenue Columbus, OH 43217
(614) 492-1614 FAX (614) 492-1618

www.walkermagnet.com

e-mail: sales@walkermagnet.com

REPLACEMENT PARTS LIST
MODEL: 57" D SCRAPMASTER II
46-405786-CH

ITEM	PART NO.	QUANTITY	DESCRIPTION
1	46-006605	1	INTERNAL LEAD
2	DD4160-14	1	CHAIN ASSEMBLY
3	39-910350	1	PIPE PLUG
4	3946-WN-101	3	LIFT PIN, MAGNET
5	46-006613	1	PROTECTOR, LEAD
6	46-004816	2	CONNECTORS
7	46-006614	1	EXTERNAL LEAD
8	46-004818	1	LOCK PIN
9	46-004815	1	PROTECTOR, CABLE
10	¾-10 X 3"	2	HEX HEAD CAP SCREW

